

Irradiation Chamber BSL-01

Manual



Version 1.3.0

Opsytec Dr. Gröbel GmbH
Am Hardtwald 6-8
D-76275 Ettlingen

Phone: +49(0)7243 / 9 47 83-50
Fax: +49(0)7243/ 9 47 83-65
info@opsytec.de

1 Table of Contents

1	Table of Contents	2
2	Preface	4
3	Quick start guide	5
4	Directives and Norms	6
5	Identification	7
5.1	Manufacturer, Ordering of Spares and Customer Service	7
5.2	Change History	7
5.3	Copyright	7
5.4	Identification of the Device.....	7
5.5	Intended Use.....	8
5.6	Foreseeable Misuse	9
5.7	Legal Information.....	10
5.7.1	Limitation of Liability	10
5.7.2	Declaration of conformity	10
5.7.3	Warranty Terms.....	10
6	General	11
6.1	Information about this Manual.....	11
6.2	Information about the Symbols	12
6.2.1	Safety Instructions	12
6.2.2	Prohibition Signs.....	12
6.2.3	Warning Signs	13
6.2.4	Attention	13
6.2.5	Fire Protection Sign	14
6.2.6	Rescue Sign.....	14
6.2.7	Optional functions	14
6.3	Owner/Operator Information	15
6.4	Personnel Requirements	16
6.4.1	Qualifications.....	16
6.4.2	Electrically skilled person.....	16
6.4.3	Qualified person	16
6.4.4	Operators	17
6.4.5	Training and Qualification of Personnel.....	17
6.5	Personal Protective Equipment.....	18
6.5.1	Protective Gloves	18
6.5.2	Protective Goggles	18
6.5.3	Safety Boots.....	18
7	Safety Information and Residual Risk	19
7.1	General	19

7.2	Safety Information Concerning Normal Operation	20
7.3	Radiation Safety.....	21
7.4	Safety Information Concerning Service and Repair Work.....	22
8	System Description	24
9	Commissioning	27
10	Operating	28
10.1	LedControl operation.....	28
10.1.1	Operation Mode.....	30
10.1.2	Led on / off – continuous irradiation mode.....	30
10.1.3	Power & Irradiance modification.....	31
10.2	Timer mode.....	31
10.3	Dose controlled mode.....	33
10.4	Setup of internal settings	34
10.5	Settings, system behavior.....	34
10.5.1	Setting the menu language	34
10.5.2	11.2.3 Settings, fan*	34
10.5.3	Version.....	35
10.5.4	internal	35
10.6	Internal settings.....	36
10.6.1	Sensor factors	36
10.6.2	Calibration*.....	36
10.6.3	Upper and lower limit / Calibration each spectral range*	37
10.6.4	Safety time*	37
11	Technical Data.....	38
12	Maintenance	40
13	Spare Parts	42
14	Declaration of Conformity.....	44

2 Preface

Dear Customer!

Thank you for choosing a product manufactured by us!

Please take your time to read this manual carefully. Please pay special attention to the safety instructions.

This is the condition for safe handling and safe operation of the system and its components.

If you have any questions that you do not find answered in this manual, please call us and we will be pleased to assist you. In addition, we always welcome any suggestions or proposals for improvement.

Our products undergo constant advanced development; therefore there may be minor differences between your system and the illustrations given in this Operating Manual.

© 2021

Opsytec Dr. Gröbel GmbH

Am Hardtwald 6-8

D – 76275 Ettlingen

Tel.: +49(0)7243 / 9 47 83-50

Fax: +49(0)7243 / 9 47 83-65

info@opsytec.de

All rights reserved. Re-printing, also extracts, only permitted with written consent of Opsytec Dr. Gröbel GmbH.

This is a translation of the original operating manual.

3 Quick start guide

The quick guide should demonstrate the installation and some of the system functions to trained personnel. You will find the detailed instructions on page 27. Please pay special attention to the safety instructions given in the complete manual.

Commissioning:

- Unpack all components and remove the packaging materials.
- The BSL-01 is supplied with mounted UV LEDs. You don't need to install them.
- Make sure that the air inlets and outlets are not covered.
- Connect the LedControl with the irradiation chamber using supplied cable.
- If Sensor was ordered:
 - Mount the sensor in the left-hand sensor holder inside the irradiation chamber.
 - Remove sensor caps.
 - Route the sensor cable through cable feedthrough in the rear side of the irradiation chamber.
 - Connect the sensor with the LedControl
- Connect the irradiation chamber with mains voltage.
- Switch on the LedControl by means of the switch on the backside of LedControl

Operation:

- Open the front door of the irradiation chamber and place the objects to be irradiated in the irradiation chamber.
- Make sure that the built-in sensor is not covered for dose-controlled radiation.
- Close the front door of the irradiation chamber, otherwise the UV LEDs won't turn on.
- Choose Operation mode: continuous irr. (irradiation), timer or dose*
- If necessary, check the irradiation intensity and use ▽ and △ keys to adjust the radiation intensity and check the sensor factor (see chapter 10.6)
- Start the irradiation by LedControl, depending on your options. At the end of the exposure open the front door of the irradiation chamber and carefully remove the irradiated objects. Don't forget to switch off LedControl.



Information on safety instructions can be found on page 19.

Information on commissioning can be found on page 27.

Information on how to operation can be found on page 28.

4 Directives and Norms



The system is machinery under Annex II A of the Machinery Directive and is therefore delivered with a declaration of conformity and with a CE mark (in accordance with the Machinery Directive).

Directives	
EC Directives	06/42/EC (Machinery) (partially observed) 2014/30/EC (EMC) 2014/35/EC (Low voltage)
Harmonized standards	
EN ISO 12100:2010	Safety of Machinery – General Principles for Design Risk Assessment and Risk Reduction

5 Identification

5.1 Manufacturer, Ordering of Spares and Customer Service

Opsytec Dr. Gröbel GmbH
 Am Hardtwald 6-8
 D – 76275 Ettlingen
 Tel.: +49(0)7243 / 9 47 83-50
 Fax: +49(0)7243 / 9 47 83-65
 info@opsytec.de
 www.opsytec.com

5.2 Change History



We reserve the right to make changes in content. Opsytec Dr. Gröbel GmbH is not liable for any errors in this documentation. No liability shall be accepted for indirect damages arising from the delivery or use of this documentation, in as far as this is legally permissible.

Version	Changed by	Date	Change
1.0.0	Paravia	14.11.2015	Release
1.0.1	Paravia	13.09.2017	Minor update
1.0.2	Paravia	02.05.2018	Maintenance and spare part update
1.3.0	Paravia	20.9.2021	Fan speed

5.3 Copyright



Opsytec Dr. Gröbel GmbH shall retain the copyright for these operating manual. The operating manual is intended for the owner/operator and his personnel.

Copyright in accordance with DIN ISO 16016:

Reproduction and copying of this document, use and disclosure of its contents are prohibited unless expressly authorized.
 Non-compliance may result in a claim for damages. All rights reserved in case of registration of patent, utility patent, or design patent.
 Contraventions may be subject to prosecution.

5.4 Identification of the Device

For internal use at customer site:

Description of machinery:	Irradiation chamber BSL-01
Year of construction:
Machine No.
Project no.

5.5 Intended Use

The BSL-01 irradiation chamber is a curing chamber for different UV applications like

- Curing of adhesives and polymers for small parts
- PCB and wafer irradiation
- Accelerated aging of plastics and similar materials with UV

The system is exclusively intended for industrial use. It is forbidden to use the devices in explosive environments or for general illumination.

- Installation, commissioning, operation, maintenance and service works must solely be performed by trained and educated, qualified personnel, which observes all safety regulations and standards.
- Responsibility: Damages resulting from unintentional or unauthorized interventions terminate every right, to raise warranty or liability claims against the manufacturer.
- Guarantee exclusion: The use of any non-original parts voids the guarantee.
- Environmental protection: Defect parts, which may contain environmentally harmful substances, must be disposed of accordingly.
- During the operation a high-energy UV and/or visible radiation is generated.
- Operation is only permitted in a dry environment. The installation is horizontal.
- Only suitable for the operation in closed rooms.
- Prior to opening, the system must be disconnected from the voltage and it must be checked that there is no voltage present.
- Wear gloves for maintenance, cleaning and exchanging the leds and optical components.
- The system must not be cleaned when in operation.
- The door must not be opened during irradiation. The front door is monitored. Should it be opened during the irradiation, the UV LEDs will automatically switch off. Since this is done with a slight delay, the user will possibly be briefly exposed to UV radiation.
- Any other use than the above mentioned, results in damages to the product. Furthermore, it is associated with risks such as short circuits, fire and electric shocks. The entire device must not be changed and/or modified! The safety notes must be observed at all times.

	⚠ CAUTION
	<p>System may fall down! Device damaging and personal injuries are possible</p> <ul style="list-style-type: none">• Always carry the system with two persons.

5.6 Foreseeable Misuse

The following is considered foreseeable misuse:

- Operation of the device without safety devices and equipment.
- Activities of uninstructed personnel on the device.
- Non-compliance with the operating instructions of the owner/operator.
- Ignoring of the operating manual.
- Any other use outside the intended specified use.

5.7 Legal Information

5.7.1 Limitation of Liability

All the information in this manual was compiled with consideration of the currently valid standards and regulations, of the technical standard and our long-standing knowledge and experience.

The manufacturer shall not be liable for damage in the event that:

- This manual is ignored,
- The device is improperly used,
- Untrained personnel is deployed,
- Untrained personnel operates the machine incorrectly,
- Unauthorized modifications are made,
- Technical changes are made,
- Non-approved spare parts are used.

We shall not be liable for common faults of the device caused by power outage or failure of the control system.

The actual scope of delivery may be different than the explanations and pictures in this manual in case of special versions, when additional options are ordered or due to the latest technical changes.

The obligations agreed in the delivery contract, as well as the legal requirements valid at the time the contract was concluded shall apply.

5.7.2 Declaration of conformity

The declaration of conformity is in the annex or can be requested from the manufacturer.

5.7.3 Warranty Terms

The warranty terms and guarantee conditions are governed by the German Civil Code (BGB). The warranty period is one year unless otherwise agreed in the purchase documents.

6 General

6.1 Information about this Manual

This manual intends to make handling of this system and its components safe and efficient. The manual is part of the system and must be kept in its immediate vicinity where it is accessible for the personnel at any time.

This documentation contains the necessary information for the intended use of the described system. It is intended for technically qualified personnel who have been especially trained for operation, laboratory use, quality assurance, service and repair.

The personnel must have read this manual carefully and understood its content before commencing any work. The basic condition for safe working is observation of all stated safety information and operating instructions in this manual.

Knowledge and technically faultless implementation of the instructions, safety requirements, safety information and warnings are a condition for safety in operation, service and repair. Only qualified personnel has the required professional knowledge to apply the safety requirements, safety information and warnings stated in this operating manual in a general way correctly in a concrete situation.

In addition, the local accident prevention regulations and general safety regulations apply for the area of application of the system.

Illustrations in this manual serve the purpose of general understanding; they may differ from the actual version.

Apart from this manual the instructions for the installed components included in the appendix apply.

This operating manual cannot take any possible case of maintenance into account. If you need further information or if special problems occur that are not treated extensively enough in this manual please request the required information from the manufacturer.



For a simple description, the above mentioned components are collectively referred to as system.

6.2 Information about the Symbols

6.2.1 Safety Instructions

In this manual, safety information is indicated by means of symbols. Safety information is preceded by signal words that indicate the scope of risk.

To avoid accidents and damage to persons or property, always follow the information and act prudently.

Throughout the text, you will find the following pictograms with the following meanings:

	⚠ DANGER
	<p>Imminent danger Possible consequences: death or most serious injuries.</p> <ul style="list-style-type: none"> • Prevention

	⚠ WARNING
	<p>Dangerous Situation Possible consequences: death or most serious injuries.</p> <ul style="list-style-type: none"> • Prevention

	⚠ CAUTION
	<p>Possible Situation Possible consequences: slight or minor injuries. Sometimes also used for warning of material damage.</p> <ul style="list-style-type: none"> • Prevention



Note

Information for use or useful important information

6.2.2 Prohibition Signs



General "Prohibited-sign"

6.2.3 Warning Signs



Warning of optical radiation
(such as UV, IR, or visible radiation)



Warning of hot surface!



Warning of electricity!

6.2.4 Attention



Wear eye protection!



Opaque eye protection must be worn!



Disconnect mains plug from electrical outlet!



Disconnect before carrying out maintenance or repair!



Use hand protection!



Wear foot protection!



Refer to instruction manual/booklet

6.2.5 Fire Protection Sign



Extinguishing hose



Fire extinguisher

6.2.6 Rescue Sign



Emergency exit: marking of all emergency exits with this symbol

6.2.7 Optional functions

* Optional functions, not available for every system

6.3 Owner/Operator Information

The System is used in the commercial sector. The owner/operator of the system is therefore subject to the legal obligations concerning work safety.

In addition to the safety information in this manual, the generally applicable regulations valid for the application area of the system concerning safety, prevention of accidents and for protection of the environment must be noted and complied with.

The following applies in particular:

The owner/operator must acquire information about the valid occupational health and safety information and in a risk assessment determine additional hazards incurred due to the special operating conditions at the location of use of the system. He must implement these in the form of operating instructions for operation of the system and specifically for the individual work stations.

The owner/operator is obliged to check during the entire lifetime of the system whether the operating instructions that he generated comply with the current status of the regulations and update them if necessary.

The owner/operator must assign and define the responsibilities for installation, operation, rectification of faults, service and cleaning unambiguously.

The owner/operator must ensure that all personnel dealing with the system have read and understood this manual. Furthermore, he is obliged to provide personnel training in regular intervals and provide information about risks.

The owner/operator must provide the required personal protective equipment for his personnel. Furthermore, the owner/operator is responsible that the system is always in faultless technical condition. To ensure this, the service intervals specified in this manual and in the technical documents for the individual systems must be observed and all safety installations must be checked regularly for function and completeness.

The owner/operator must have all safety devices checked regularly for function and completeness.

The owner/operator must ensure that the operating personnel have knowledge about first aid measures and local rescue installations.

6.4 Personnel Requirements

6.4.1 Qualifications

	⚠ WARNING
	<p>Risk of injury when personnel are insufficiently qualified!</p> <p>If unqualified personnel carries out work on the system or stays in the danger area of the system risks arise that may cause severe injuries and serious material damage.</p> <ul style="list-style-type: none"> • Have all activities carried out only by personnel qualified for the activity. • Keep unqualified personnel away from the danger area.

	⚠ WARNING
	<p>Risk of injury when touching live parts or hot surfaces</p> <p>Generally, low voltage devices like this system can have dangerous live parts and hot surfaces. All works for transportation, installation, commissioning, start-up and maintenance must be performed by respectively trained and responsible, qualified personnel (in accordance with EN 50110-1 (VDE 0105-100); IEC 60364). Inappropriate behavior can lead to serious injuries or damages.</p> <p>During the irradiation the LED temperature may rise up to approx. 60° C. Caution - risk of burns.</p>

Below, this manual lists the qualifications of the personnel for the various areas of activity:

6.4.2 Electrically skilled person

Due to their professional training, knowledge and experience and knowledge of the relevant standards and regulations, electrically skilled persons are able to carry out work on electrical systems and to recognize and avoid risks independently.

Electrically skilled persons are specially trained for the work environment where they are working and they know the relevant standards and regulations. Electrically skilled persons must fulfil the requirements of the valid legal regulations for accident prevention.

6.4.3 Qualified person

Qualified persons are trained or can be trained by Opsytec Dr. Gröbel GmbH in extended operation and parameterization of the system as well as in execution of preventive service work.

In addition, due to their technical training, knowledge and experience and knowledge of the relevant standards and regulations, they are able to carry out work they have been assigned and to recognize and avoid possible risks independently.

6.4.4 Operators

Operators use and operate the system in the scope of the intended use. They are trained by the owner/operator in the work assigned to them and informed about possible risks.

6.4.5 Training and Qualification of Personnel

In regular instructions and training, operating personnel must be informed about the special risks when working with and handling the system.

The instruction and training should have the following content:

- Hazards when working with the system in normal operation.

- Hazards in connection with service, repair and cleaning activities.

- Conduct to minimize consequences of accidents.

- Conduct in case of accidents.

- Rescue of injured persons.

- Working without personal protective equipment may cause health damage. The company supervisor is instructed to pay attention that personnel are wearing personal protective equipment.

- Particular hazards when working on the electrical system.

Instruction and training must be carried out in regular intervals by the owner/operator. For better tracking, execution of instruction and training should be recorded.

6.5 Personal Protective Equipment

The purpose of personal protective equipment is to protect the personnel from risks that might affect his safety or health when working.

When executing various activities on and with the system, the personnel must wear personal protective equipment. This will be pointed out again in the individual chapters of this manual. Below, personal protective equipment is explained:

6.5.1 Protective Gloves

Protective gloves are used to protect hands from visible and invisible radiation, friction, abrasion, stabs and deep injuries.

6.5.2 Protective Goggles

Protective goggles are used to protect eyes from intense visible and invisible radiation.

6.5.3 Safety Boots

Safety boots are used as protection from heavy parts falling down and slipping on slippery surfaces.

7 Safety Information and Residual Risk





7.1 General



The system is state-of-the-art and has been built in compliance with recognized safety regulations. Nonetheless, its use may constitute risks for life and limb of the operating and repair personnel (service personnel) or third parties or impairments to the machine. Operate the system only when its safety devices are in faultless condition. Disruptions that impair its safety must be rectified at once.

The following safety information must be strictly observed to prevent damage to the machine and personal injury!

	⚠ WARNING
	<p>Risk of injury when personnel do not read the operation manual! Prior to commissioning and operation, read the operation manual completely. Read all safety information and instructions. Negligence concerning safety information and instructions may cause electric shock and/or severe injuries.</p>

7.2 Safety Information Concerning Normal Operation

	<p style="text-align: center;">⚠ DANGER</p> <p>Danger to life Danger to life occurs when the system is operated with defective or absent safety devices.</p> <ul style="list-style-type: none"> The system should be operated only when all protective devices and safety-related installations are present and in working condition. The operator of the machine is obliged to check the safety devices for proper function regularly before production is started.
	<p style="text-align: center;">⚠ WARNING</p> <p>Risk of Fire! An extremely high irradiance, which can ignite combustible materials in cases of permanent radiation, is reached inside at the top of the irradiation chamber. Do not place any combustible material direct under the LEDs and observe the irradiation time and the material temperature.</p>
	<p style="text-align: center;">⚠ WARNING</p> <p>Risk of injury when touching hot surfaces During the irradiation the LED temperature may rise up to approx. 60° C. Caution - risk of burns.</p>
	<p style="text-align: center;">⚠ CAUTION</p> <p>Risk of Damage</p> <ul style="list-style-type: none"> Skin fat and dirt are absorbent in the UV and visible spectral range. Avoid fingerprints on the optically active sensor surface. If necessary, the components must be cleaned carefully with Isopropyl. Use safety goggles and gloves when working inside sample room of the BSL-01 irradiation chamber.

 CAUTION	
	<p>Risk of Damage The system warms up during operation.</p> <ul style="list-style-type: none"> • Make sure that there is an adequate air circulation at the installation site. • Air vents in the device housing and the LED modules must not be covered.

For activities in normal operation a brightness of at least 300 Lux must be provided.



Access to the machine is only permitted for operating personnel and instructed personnel.

Operation the machine is only permitted for instructed operating personnel.

Removing or disabling protective devices is not allowed during operation of the system.

If any protective devices or equipment fail or have become faulty, this must be reported to the operations supervisor immediately. He will decide about further procedure.

7.3 Radiation Safety

 WARNING	
	<p>Risk of eye injury UV-radiation is harmful! Always wear suitable safety glasses. Avoid direct exposition.</p> <p>This product is equipped with UV and visible high intensity LEDs. There is a risk of photo-chemical or thermal damage of the eye, retinal damage of the eye and erythema. The operating staff is to be trained appropriately.</p> <p>For protection of the operating staff, do not look into the UV light and do not expose the skin continuously to UV radiation.</p> <p>Note: In case of a malfunction, the UV light can be switched on, even though the status LEDs or the trigger output does not signalize this. Before working with the device, please check that the LEDs are switched off.</p>



7.4 Safety Information Concerning Service and Repair Work

	⚠ WARNING
	Risk of injury! High Weight! Always carry the system with two persons.

	⚠ WARNING
	Risk of injury when touching live parts Before opening the system, disconnect all components from the supply voltage and check that no voltage is present.

	⚠ CAUTION
	Risk of Damage <ul style="list-style-type: none">• Switch off the control unit prior to connecting / disconnecting accessories. Due to the operating voltage of the unit, the accessories can get damaged.• Unplugging & plugging of signal cables during the operation is strictly forbidden!

	⚠ CAUTION
	Risk of Damage <ul style="list-style-type: none">• Skin fat and dirt are absorbent in the UV and visible spectral range.• Avoid fingerprints on the optically components, sensor surfaces, LEDs and reflectors. If necessary, the components must be cleaned carefully with Isopropyl.

 CAUTION	
	<p>Risk of Damage</p> <p>The system warms up during operation.</p> <ul style="list-style-type: none">• Make sure that there is an adequate air circulation at the installation site.• Air vents in the device housing must not be covered.

Service, repair and cleaning work must only be carried out by authorized and specifically trained professionals. The system must be power-free and secured before major work is carried out (including cleaning).

Carry out the prescribed setting, service and inspection work according to schedule. If you need further information or if special problems occur that are not treated extensively enough in this manual please request the required information from the manufacturer.

Only specialized electricians may perform work on electrical equipment.

Safety devices may only be removed during service and repairs, if the system was previously switched off and brought into a safe condition.

For service and maintenance work, important safety installations may not be functional. Work of this kind therefore requires special caution.

8 System Description

BSL-01 is a versatile irradiance chamber on a basis of high quality UV LEDs. The most common UV curing adhesives can be applied, due to the high irradiance. The high irradiance allows for very short exposure times.

With the typical UV LED characteristics like „Instant-Start“, the dimmability and the long service life, the BSL-01 is ideal for laboratory tests and the manual production. The exposure in the BSL-01 is carried out time- or dose-controlled by the LedControl.

For different applications, wavelengths of 365 nm, 385 nm, 395 nm, 405 nm and 450 nm are available.

Due to the low heat input of the UV-LEDs and the temperature of approximately 40° in the sample chamber, thermal damages of the samples are minimized. Because of the high homogeneity of the irradiance, the samples can be placed in any position.

The BSL-01 has compact outer dimensions, but provides sufficient room in the sample chamber.

In the completely closed and monitored irradiation chamber, the operating personnel are fully protected from the UV radiation.

The components at a glance:

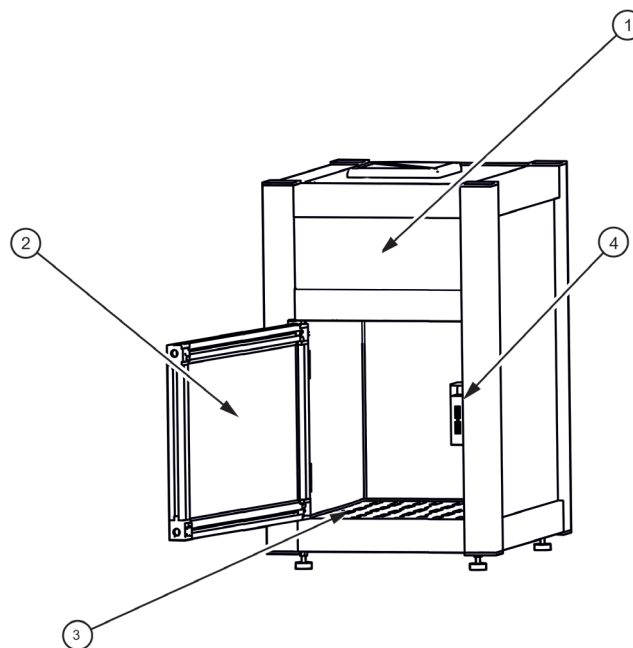

Pos.	Designation	Pos.	Designation
1	Irradiation chamber	2	Front door
3	Sample plane	4	Door contact

Rear view and ventilation concept:

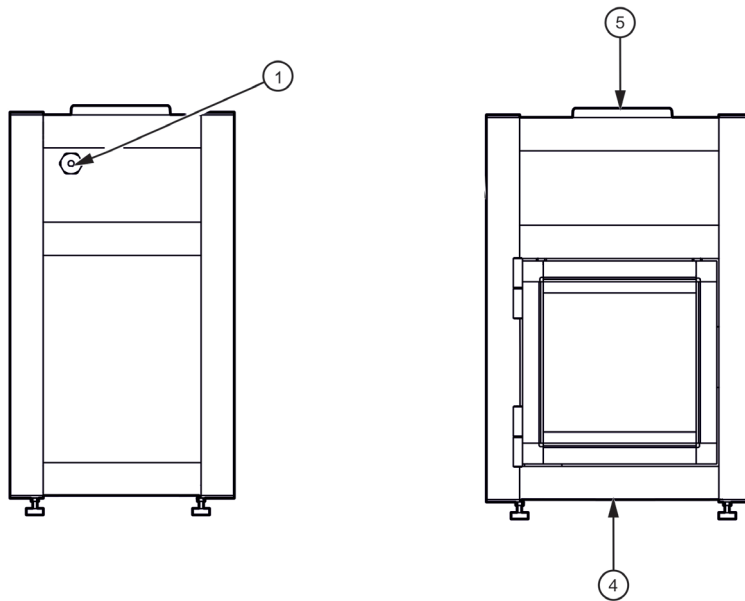

Pos.	Designation	Pos.	Designation
1	Connector for LedControl	4	Air inlet for samples
5	Air outlets		



(1)

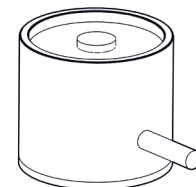

(2)

Pos.	Designation	Pos.	Designation
1	LedControl	2	Sensor

The LedControl unit contains the power supply, the microcontroller system with display and keyboard and the output controls. The sensor is connected to the backside of the LedControl unit.

The sensors are adapted to the leds, meaning UVA+ sensor for UVA leds for example. The sensors are cosine corrected. Due to the excellent cosine correction it is possible to measure from a side position.

The following components are delivered:

- Irradiation chamber
- LedControl
- Connection cable for chamber and LedControl
- Power line cable
- This documentation



For a simple description, the above mentioned components are collectively referred to as system.

The following components are required by the customer:

- none

9 Commissioning

- Unpack all components and remove the packaging materials.

	⚠ WARNING
	Risk of injury! High Weight! Always carry the system with two persons.

- The BSL-01 is supplied with mounted UV LEDs. You don't need to install them.
- The BSL-01 uses a ventilation system. Make sure that the air inlets and outlets are not covered.
- Connect the LedControl with the irradiation chamber using supplied cable.

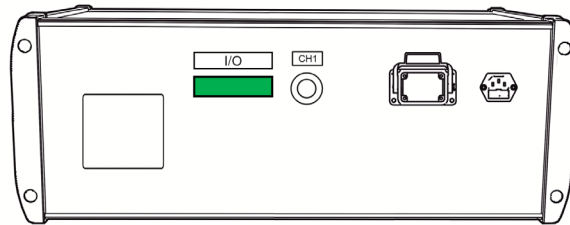

- If Sensor was ordered:
 - Mount the sensor in the left-hand sensor holder inside the irradiation chamber.
 - Remove sensor caps.
 - Route the sensor cable through cable feedthrough in the rear side of the irradiation chamber.
 - Connect the sensor with the LedControl
- Connect the irradiation chamber with mains voltage.
- Switch on the LedControl by means of the switch on the backside of LedControl
- BSL-01 is completely operated by LedControl.

10 Operating

The irradiation chamber is switched on with the power switch on the LedControl (rear side). According to your included options the operation may vary. Options are:

- Sensors and sensor holder
- Dose control function (normally called UV-MAT)

In general:

- Open the front door of the irradiation chamber and place the objects to be irradiated in the irradiation chamber.
- Make sure that the built-in sensor is not covered for dose-controlled radiation.
- Close the front door of the irradiation chamber, otherwise the UV LEDs won't turn on.
- Start the irradiation by LedControl, depending on your options. At the end of the exposure open the front door of the irradiation chamber and carefully remove the irradiated objects. Don't forget to switch off LedControl.

10.1 LedControl operation

The LedControl is operated via five keys. These keys are arranged in the front, right next to the display. The keys and the function configuration are shown below:

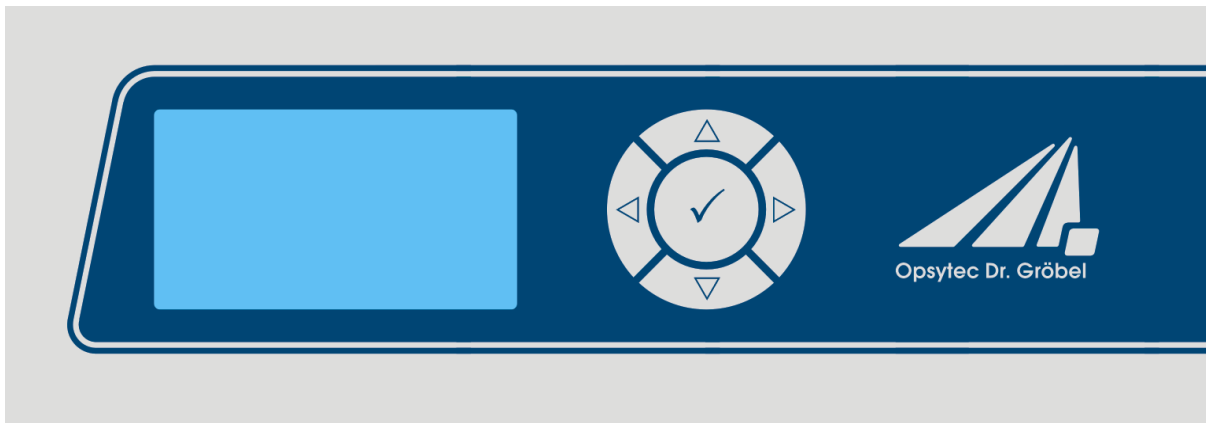

Key	Function
▽	Down
△	Up
◁	Left
▷	Right
✓	Confirm / OK

Initially after starting the device, the logo appears in the display for 2 seconds.



Now the device is in standby and is displayed in the main menu.

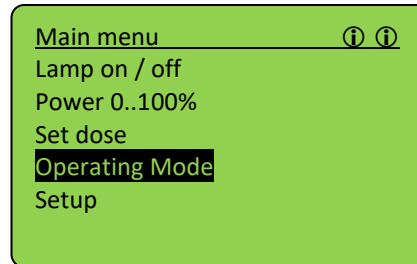

The menu items in the main menu depend upon the settings, i.e. the menu items “Performance 0..100%” and “Irradiation time” are only displayed, when the respective mode has been selected.

In the main menu and all other menus, select the active menu item via the keys ∇ and \triangle . By clicking \checkmark you confirm the selected menu item. With \triangleleft you return to the previous menu without adopting the changes.

The selected menu item is displayed on a black background and inverted.

The status is displayed in the upper right corner (\textcircled{i} \textcircled{i}). The symbols below have the following meaning:

- \textcircled{o} LED Module On
- \textcircled{o} LED Module Off
- \textcircled{a} External set point for the LED performance (optional)
- \textcircled{a} Internal set point for the LED performance
- \textcircled{t} Timer mode
- \textcircled{c} Continuous operation
- D Dose mode

10.1.1 Operation Mode

LedControl offers three operation modes:

- Continuous irr. (irradiation)
- Timer
- Dose* (sensor necessary)

Using this menu you can set the operation mode settings.

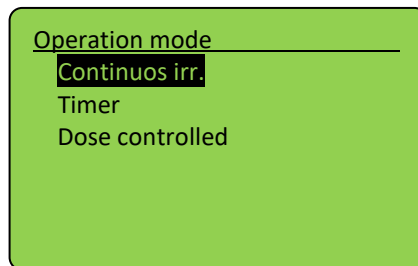

10.1.2 Led on / off – continuous irradiation mode

Close the door before switching LEDs on. Afterwards select “Lamp On/Off” and press ✓. When the LEDs are switched on, the status monitor is shown in the display. Example:

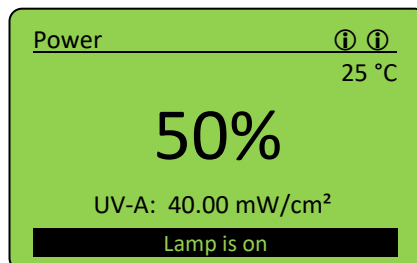

By clicking (✓) the LED is switched off.

With the keys ▾ and ▴ the power can be modified during the operation.

The status monitor displays the actual performance, the internal or external control and error messages.

From the status menu you can return to the main menu by pressing ◀.

10.1.3 Power & Irradiance modification

In the main menu select the menu item “Power 0..100%”. In the submenu you can select the decimal with the keys ◀ or ▶ and set the power with the keys ▲ or ▼ to the desired value. Confirm with OK (✓) to return to the main menu.

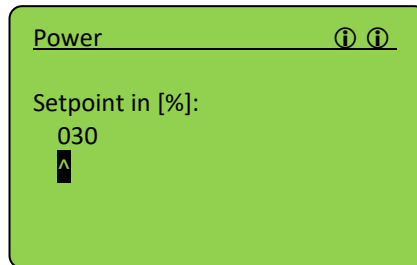

Settings below 2% and above 100% are reset to the threshold values



Power settings can be changed during irradiation with keys ▲ or ▼.

10.2 Timer mode

In the menu “Irradiation Time” you can set the irradiation time for the timer. Therefore select menu item “Set time”. If “Set time” is not displayed, please choose “Timer” in menu “Operation Mode” first.

Now you can select the decimal with the keys ◀ or ▶ and with the keys ▲ or ▼ you can set the time to the desired value. Confirm with OK (✓) to return to the main menu.

In timer mode you can set the duration of irradiation:

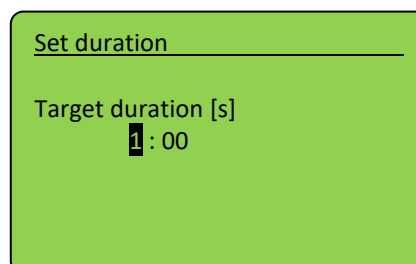

In timer mode, the LED is started for the pre-set exposure time and it switches off automatically afterwards. By clicking (✓), you can abort the exposure. Start irradiation with “Start/Stop”

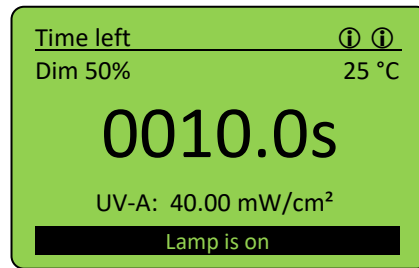

By clicking (✓) the LED is switched off.

With the keys ▾ and ▴ the power can be modified during the exposure.



By clicking (✓) the exposure is aborted.

The maximum duration is 9999 s.

In time controlled mode the irradiation time controlled by a timer only. On the display the irradiation time and, if sensor is connected the irradiance, are displayed. A sensor is not necessary for timer mode.

10.3 Dose controlled mode

Select operation mode dose.

Confirm by with ✓ or ▷. With ◀ you can cancel your input and go back to main menu.



In dose controlled mode the irradiation time is automatically controlled and stops if the desired dose is reached. Note a sensor must be connected therefore.

Set the target dose for an irradiation:

Set dose

Set dose in [J/cm²]:
10.0000
▲



Use the ◀ key to add a digit.

Use △ and ▽ keys to change value and confirm with ✓.

Return to main menu and start an irradiation by selecting "Start Radiation".

In dose controlled operation mode the current irradiance in mW/cm², the actual irradiation time, the current dose (Is:) and the target dose (Set:) are displayed:

Dose controlled ⓘ ⓘ

UV-A: 5.05 mW/cm²
 Time: 00 : 00 : 00 : 50
 Is: 0.002507 J/cm²
 Set: 10.0000 J/cm²

25 °C



mW/cm² and J/cm² are automatically calculated.

Stop an irradiation by pressing ✓ for at least 2 seconds.

10.4 Setup of internal settings

10.5 Settings, system behavior

Using this menu you can set the system settings and display LED temperature.

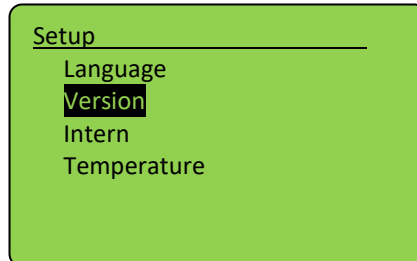

10.5.1 Setting the menu language

The menu languages German and English are available. The setting is taken out in the menu "Settings", then click on "Language".

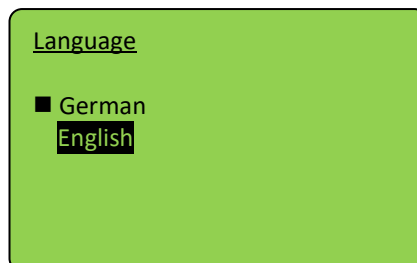

Select the desired language with the keys ∇ and \triangle and confirm with \checkmark .

10.5.2 11.2.3 Settings, fan*.

For lower powered requirements, the fan speed and thus both the cooling power and the noise emission can be reduced.

Two ventilation levels are included:

- Exposure
- Basic

The fan speed can be set separately in both ventilation levels.

In addition, an after-irradiation cooling time can be set in minutes and seconds. The after-irradiation cooling time uses the "Exposure" ventilation stage for additional cooling after the exposure has been completed.



Your system may be equipped with a parameter lock so that no fan speeds that are too low can be selected.



The temperature monitoring is independent of the fan speed and can, if a critical temperature is exceeded, temporarily deactivate the ventilation stage and increase the fan speed to protect the system.

10.5.3 Version

This will show installed firmware version:

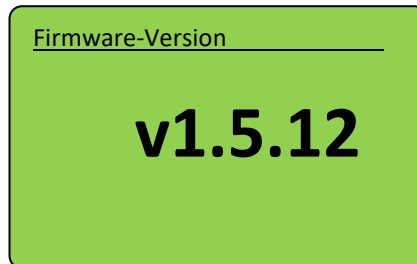

10.5.4 internal

To enter menu type in the PIN code, see *next chapter*.

10.6 Internal settings

Using this menu you can set the system settings. Therefore enter the PIN code, see *chapter technical data*, must be entered.

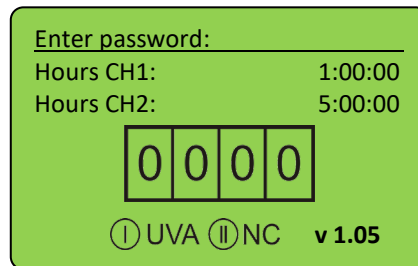

Even without PIN the operational hours, connected sensors and firmware version are displayed. After entering PIN and confirmation with OK you can change system settings:

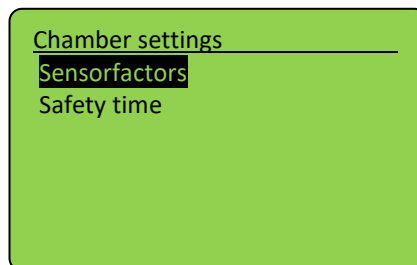

10.6.1 Sensor factors

In this submenu the sensor specific adjustments are placed. It is possible to do the sensor adjustment and set the upper and lower limits.

10.6.2 Calibration*

The calibration factor is used to calculate the irradiance for another place then the sensor place. For example:

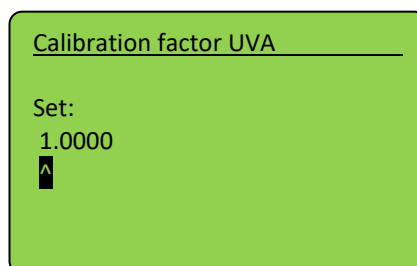

The standard value for this is 1.000 (one). Therefore the irradiance is the irradiance at the sensor place.

If you want to convert the reading for another position you have to measure the irradiance in the target position and in the sensor position. The result of the division from the target value and the sensor value is the necessary calibration factor.

Navigate with \triangleleft , \triangleright and set value with \triangle , ∇ . Confirm with \checkmark to go back to setup menu.



Use the < key to add a digit.

10.6.3 Upper and lower limit / Calibration each spectral range*

The upper and lower limits have the function of monitoring the sensors. For example:

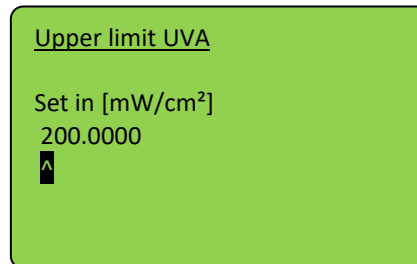

For the determination of the limit values you have to set the upper limit on e.g. 300 mW/cm² and the lower limit on 0 mW/cm². No error can occur with this setup (if the calibration factor is set to 1.0). After an adequate warm up time you have to read the values and can now adjust the upper and lower limit e.g. $\pm 25\%$ of the sensor value. Strong fluctuations during the warming up should be faded out with the delay time.

10.6.4 Safety time*

Timing values can be adjusted in menu "safety time". See delay time, max. time and waiting time.

Delay time*

The delay time is the time, which the UV-Mat waits until it starts to monitor the sensor signal. It should be as long as the leds need to get on a constant irradiancy delivery.

Max. time*

Max. time is a safety function. After reaching this time the irradiation is stopped.

Waiting time*

The waiting time is the time after the irradiation which must be waited to start a new irradiation. This time should be so long, that double irradiation is to be excluded. It should be set at least to **3 seconds** to prevent immediate user restart.

11 Technical Data

General data	
Ambient temperature	10 to 40 °C
Storage temperature	-10 to 60 °C
Humidity	< 80% non-condensing
Cooling	Air cooling
Maximum housing temperature	< 60 °C
Sample temperature	~40 °C +/- 10 °C. Add. heating up by UV irradiance
Dimensions, chamber	~ 28 x 34 x 43 cm (L x T x H)
Dimensions, LedControl	~ 36 x 34 x 14 cm
Weight, chamber	~20 kg
Weight, LedControl	~ 4 kg
Type	tabletop device

Installation, minimum clearances	
Installation of the system	horizontal
Minimum clearance, above	4 cm
Minimum clearance, lateral	4 cm

Power Supply and Connections	
Operating voltage and frequency	100 - 240 V, 50/60 Hz
Maximum input power	up to 750 W
Connection irradiation chamber	rear Harting plug
Control input	24 V, input current < 20 mA High level > 15 V, positive logic Low level < 12 V
I/O connector (optional)	Phoenix Contact MC 1,5/15-STF-3,81 part number: 18 27 83 9

PIN	
code	7243

Interface I/O Option PIN Allocation*		
Interface, rear control	Signal	Interface, rear control
Pin 1	Interlock Out (5V)	Interlock
Pin 2	Interlock In (5V)	
Pin 3	+24 V	Supply voltage
Pin 4	GND	
Pin 5	Not Connected	-
Pin 6	Not Connected	
Pin 7	Trigger IN (24V)	Slave mode, steady operation or timer mode
Pin 8	Trigger OUT (24V)	
Pin 9	GND	
Pin 10-15	Not Connected	-
Pin 14	+24 V (fan cable 1)	Supply voltage for housing fans
Pin 15	GND (fan cable 2)	

External control*	
Trigger input	Connecting trigger input (PIN7) with +24V activates a trigger.
Continuous operation	The LED is lit, as long as a trigger signal is activated.
Trigger operation	The activation of a trigger („positive edge“) starts the irradiance with the set duration.
Constant mode	Internal optical photodiode is calibrated to external reference (sensor) value and keeps irradiance constant (within system limits)
Analogue input	0 .. 10 V
LED power	0 V = 2%, 10V = 100%

12 Maintenance

The BSL-01 is a combined system that needs only cleaning and recalibration as maintenance.

For cleaning we recommend to make this only on demand and not on a regular base as the side mirrors and sensor surface are sensitive to scratches.

Please use Isopropanol in a UV IR grade to clean sensors.

Mirrors are cleaned by pressurized air or Isopropanol and a very soft paper towel.

Also UV-LED cleaning is not possible.

As this is a combined system we need BSL-01 and LedControl in case of repair. Some spare parts can be changed by customer. Note, it is not recommended to change UV-LEDs by yourself. Warranty on spare parts will only be provided if installation and service is done by us.

For recalibration we need the sensor only.

The following table gives some maintenance steps as recommendation:

No.	Maintenance Item	Procedure	Recommended frequency
1	Overall Checking and Cleaning of the machine	Cleaning of bottom side from process chamber. Accumulated dust clean-up, rust check, peeled paint check, leak, broken switch, and damaged covers, otherwise replace it.	Semi-Annual
2	Sensor Checking	1. Check sensors, must be free from dirt, otherwise clean / recalibrate it.	Monthly
3	Optical Components Cleaning	0. Visual inspection of mirrors. Mirrors must be clean. Small dirt can be accepted as the mirrors are sensitive to scratches. Clean only on demand.	Monthly
		1. In case cleaning is needed, use pressurized air or Isopropanol (UV-IR Grade) and a very soft paper towel. Softly clean mirror from left to right, top to bottom. Must be free from cracks and dirt, otherwise replace to new one.	On Demand
4	Door contact checking	Verify and check door contact by its physical appearance. Replace if necessary.	Semi-Annual
5	Intensity Checking	Check and get the actual irradiance of the machine using UV sensor (must be calibrated). (Write Value)	Monthly
6	Led Change	Send UV LED chamber to manufacturer if irradiance is not high enough. UV-LED cleaning is not possible.	On Demand
7	Calibration	1. Check for calibration by comparison measurement or calibration date.	Annual
		2. Send to manufacturer if recalibration is necessary.	
8	Wiring Check	Check all wiring connection for any possible damage or loose connection. Replace if necessary.	Every 6 Weeks
9	Cleaning	Clean the machine body (outside) using wiper to remove dust and dirt	Daily

13 Spare Parts



When ordering spare parts, please contact:

Opsytec Dr. Gröbel GmbH
 Am Hardtwald 6-8
 76275 Ettlingen
 Germany
 Phone +49 - 7243 - 94 783 - 50
 Fax +49 - 7243 - 94 783 – 65

Visit our website at: www.opsytec.com

The following spare parts are available for your system:

Designation	Part Number	Pos.
LED Light source on PCB	860801L-LED + specify serial number	1
Air inlet filter set	860801L-AIF	2
Air inlet cover set	860801L-AIC	2
Left internal side mirror	860801L-BM	3
Back internal side mirror	860801L-RM	4
Right internal side mirror	860801L-RM	5
Air outlet fan	860801L-AOF	6
Air outlet filter set	860801L-AOF	6
Air outlet cover set	860801L-AOCS	6
Connector end caps for cables	860801L-EC	7
Bottom plate	860801L-BP	8
Front door with internal mirror	860801L-Door	9
Door contact	860801L-DC	10
LedControl	860801L-LC + specify serial number	11
Sensor	See sensor type	12
Sensor recalibration	710001	13
Sensor recalibration, DAKKS	17025	14
Other Parts	On request	NA

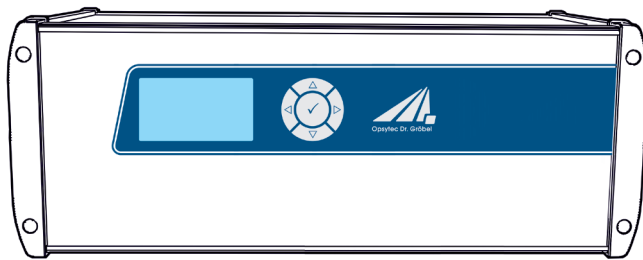
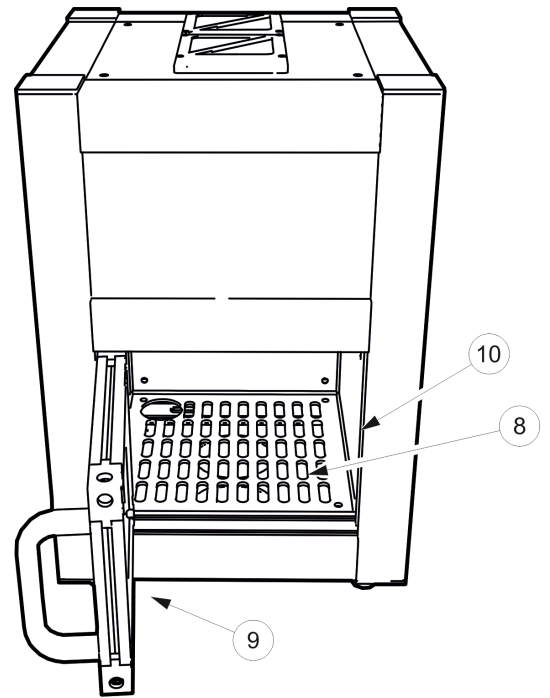
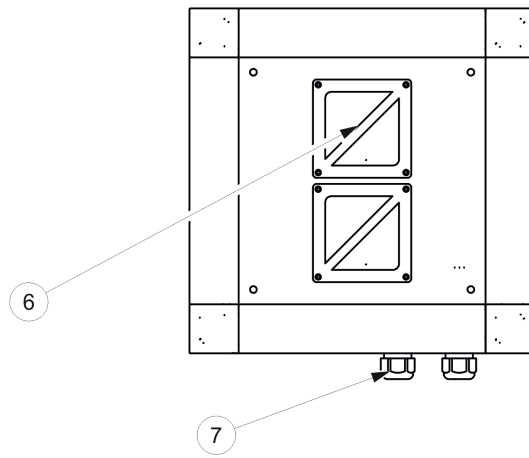
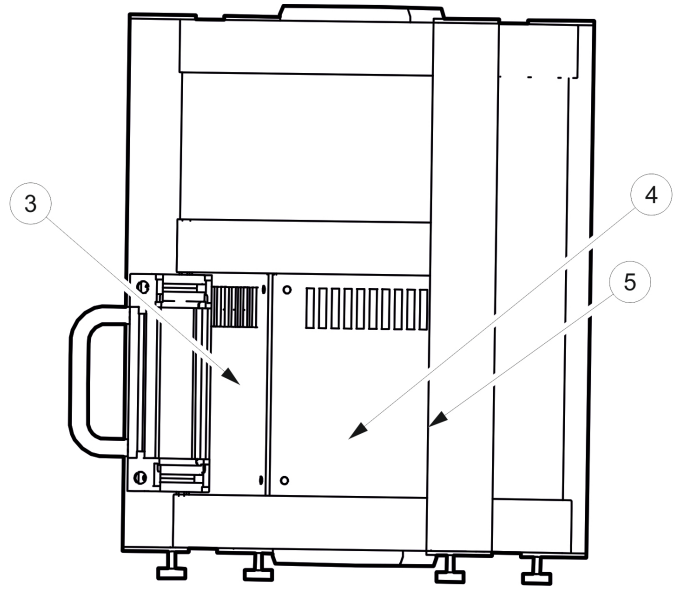
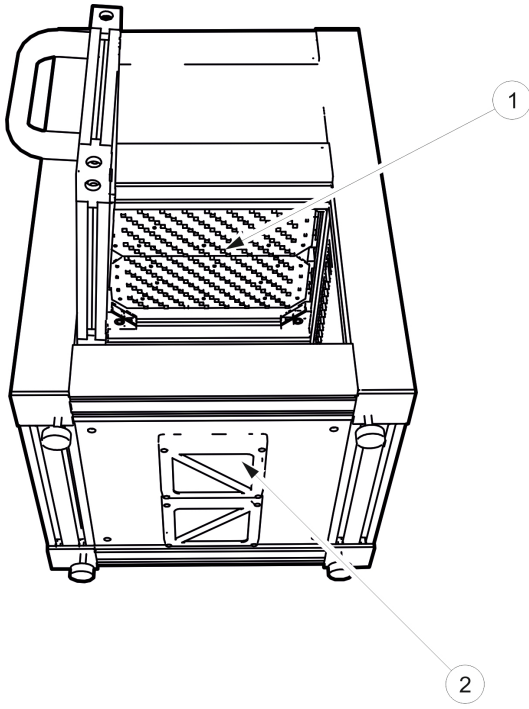

(11)

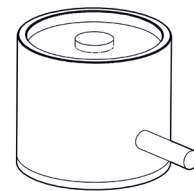

(12) (13)

14 Declaration of Conformity

Hereby we,

**Opsytec Dr. Gröbel GmbH
Am Hardtwald 6-8
76275 Ettlingen**

declare that the following product

Irradiation Chamber BSL-01

Type designation:

Irradiation Chamber 860801L with LedControl and sensor

have been developed, constructed and produced under our sole responsibility and that the product is conform with the following standard(s) or guideline(s) in this declaration:

2014/35/EU

“Directive of the European Parliament and of the Council on the harmonization of the laws of the Member States regarding the provision of electrical equipment for use within certain voltage limits on the market (Low-Voltage Directive)“.

2006/42/EG

“Directive of the European Parliament and of the Council on machinery and amending Directive 95/16/EG (Machinery Directive)“.

Ettlingen, 19.10.2015

Dr. Mark Paravia
Executive Board