

# *Irradiation Chamber BSH-02*

## *Manual*

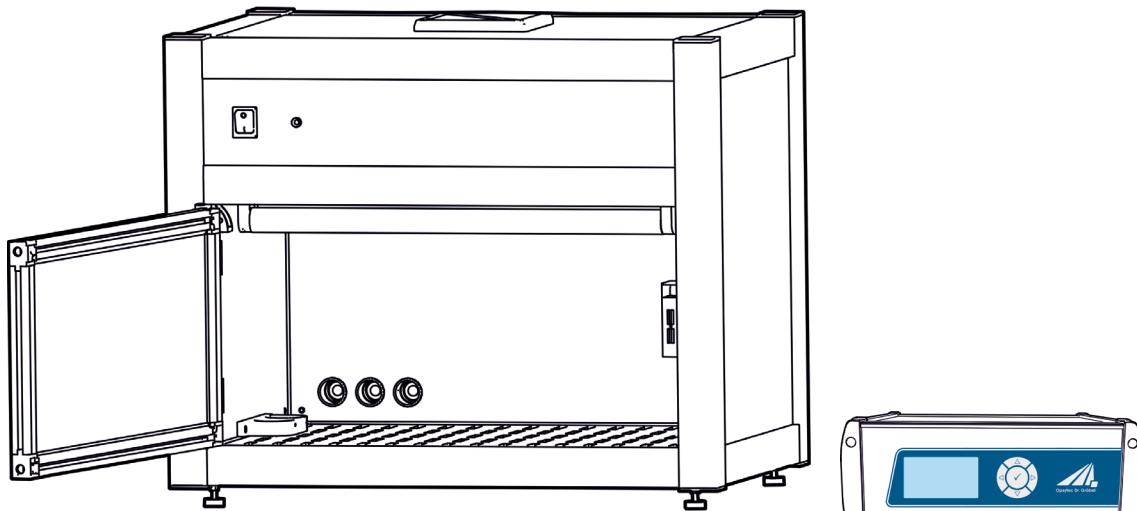

(Image similar)

Version 3.0.0E

Opsytec Dr. Gröbel GmbH  
Am Hardtwald 6-8  
D-76275 Ettlingen

Phone: +49(0)7243 / 9 47 83-50  
Fax: +49(0)7243/ 9 47 83-65  
info@opsytec.de

# 1 Table of Contents

<b>1</b>	<b>Table of Contents</b> .....	<b>2</b>
<b>2</b>	<b>Preface</b> .....	<b>5</b>
<b>3</b>	<b>Quick start guide</b> .....	<b>6</b>
<b>4</b>	<b>Directives and Norms</b> .....	<b>8</b>
<b>5</b>	<b>Identification</b> .....	<b>9</b>
5.1	Manufacturer, Ordering of Spares and Customer Service .....	9
5.2	Change History .....	9
5.3	Copyright .....	9
5.4	Identification of the Device.....	9
5.5	Intended Use .....	10
5.6	Foreseeable Misuse .....	11
5.7	Legal Information .....	12
5.7.1	Limitation of Liability .....	12
5.7.2	Declaration of conformity.....	12
5.7.3	Warranty Terms.....	12
<b>6</b>	<b>General</b> .....	<b>13</b>
6.1	Information about this Manual .....	13
6.2	Information about the Symbols .....	14
6.2.1	Safety Instructions .....	14
6.2.2	Prohibition Signs .....	14
6.2.3	Warning Signs .....	15
6.2.4	Attention .....	15
6.2.5	Fire Protection Sign.....	16
6.2.6	Rescue Sign .....	16
6.2.7	Optional functions.....	16
6.3	Owner/Operator Information .....	17
6.4	Personnel Requirements .....	18
6.4.1	Qualifications .....	18
6.4.2	Electrically skilled person .....	18
6.4.3	Qualified person .....	18
6.4.4	Operators .....	19
6.4.5	Training and Qualification of Personnel .....	19
6.5	Personal Protective Equipment .....	20
6.5.1	Protective Gloves .....	20
6.5.2	Protective Goggles .....	20
6.5.3	Safety Boots .....	20
<b>7</b>	<b>Safety Information and Residual Risk</b> .....	<b>21</b>
7.1	General .....	21

7.2	Safety Information Concerning Normal Operation .....	22
7.3	Radiation Safety .....	24
7.4	Safety Information Concerning Service and Repair Work.....	25
<b>8</b>	<b>System Description .....</b>	<b>27</b>
<b>9</b>	<b>Commissioning .....</b>	<b>31</b>
9.1	Installing and replacing a lamp .....	32
<b>10</b>	<b>Commissioning and Use of inter box* .....</b>	<b>34</b>
<b>11</b>	<b>Operating .....</b>	<b>35</b>
<b>12</b>	<b>UV-MAT operation.....</b>	<b>36</b>
12.1	Switching on .....	37
12.2	Switching off .....	37
12.2.1	Operation Mode.....	37
12.2.2	Start / Stop Radiation .....	38
12.2.3	Timer mode .....	40
12.3	Dose controlled mode.....	41
12.4	Dimming .....	42
12.5	Setup of internal settings .....	42
12.6	Settings, system behavior.....	42
12.6.1	Channel control .....	43
12.6.2	Chamber factor.....	44
12.6.3	Units .....	45
12.6.4	Setting the menu language .....	45
12.6.5	Status .....	45
12.6.6	Sensor Info .....	46
12.6.7	USB-Settings.....	46
12.6.8	Dec.-separator.....	46
12.7	Internal settings .....	47
12.7.1	Safety time .....	47
12.7.2	Operating hours.....	48
12.7.3	Sensor errors.....	48
<b>13</b>	<b>Remote Operation* .....</b>	<b>49</b>
13.1	Software Installation .....	50
13.2	Connecting with the PC .....	50
13.3	Software - UV-MAT Control .....	50
13.4	Working with the software.....	53
13.5	Datalogging* .....	55
<b>14</b>	<b>Maintenance .....</b>	<b>56</b>
14.1	Calibration.....	58
14.2	Errors / Malfunctions.....	58

15 Technical Data.....59

16 Spare Parts .....64

17 Declaration of Conformity.....65

## 2 Preface

Dear Customer!

Thank you for choosing a product manufactured by us!

Please take your time to read this manual carefully. Please pay special attention to the safety instructions.

This is the condition for safe handling and safe operation of the system and its components.

If you have any questions that you do not find answered in this manual, please call us and we will be pleased to assist you. In addition, we always welcome any suggestions or proposals for improvement.

Our products undergo constant advanced development; therefore there may be minor differences between your system and the illustrations given in this Operating Manual.

© 2020

Opsytec Dr. Gröbel GmbH

Am Hardtwald 6-8

D – 76275 Ettlingen

Tel.: +49(0)7243 / 9 47 83-50

Fax: +49(0)7243 / 9 47 83-65

info@opsytec.de

All rights reserved. Re-printing, also extracts, only permitted with written consent of Opsytec Dr. Gröbel GmbH.



This is a translation of the original operating manual.

### 3 Quick start guide

The quick guide should demonstrate the installation and some of the system functions to trained personnel. You will find the detailed instructions on page 31. Please pay special attention to the safety instructions given in the complete manual.

Commissioning:

- Unpack all components and remove the packaging materials.
- High-energy ultraviolet radiation and, with ozone generating lamps, ozone are produced during of operation!

 <b>DANGER</b>	
	<p><b>Imminent danger by Ozone</b></p> <p>When using ozone-generating lamps, the exhaust air can be enriched with ozone. Ozone is harmful to health when inhaled in high concentrations through the lungs and long periods of time. Always avoid inhaling ozone.</p> <p>A suitable drainage and treatment of waste air must be ensured so that the permissible ozone workplace concentration (MAK value) is not exceeded.</p> <ul style="list-style-type: none"> <li>•</li> </ul>

- The BSH-02 is supplied with unmounted UV lamps. You need to install them.
- Make sure that the air inlets and outlets are not covered.
- Connect the UV-MAT with the irradiation chamber using supplied cable.
- Connect the sensor:
  - Mount the sensor in the left-hand sensor holder inside the irradiation chamber.
  - Remove sensor caps.
  - Route the sensor cable through cable feedthrough in the rear side of the irradiation chamber.
  - Connect the sensor with the UV-MAT
- Connect the irradiation chamber with mains voltage.
- Switch on the system.

Operation:

- Open the front door of the irradiation chamber and place the objects to be irradiated in the irradiation chamber.
- Make sure that the built-in sensor is not covered for dose-controlled radiation.
- Close the front door of the irradiation chamber, otherwise the UV LAMPs won't turn on.
- Choose Operation mode: continuous irr. (irradiation), timer or dose\*
- If necessary, check the irradiation intensity and use ▽ and △ keys to adjust the radiation intensity.

- Start the irradiation by UV-MAT, depending on your options. At the end of the exposure open the front door of the irradiation chamber and carefully remove the irradiated objects. Don't forget to switch off UV-MAT.



Information on safety instructions can be found on page 21.

Information on commissioning can be found on page 31.

Information on how to operation can be found on page 35.

## 4 Directives and Norms



The system is machinery under Annex II A of the Machinery Directive and is therefore delivered with a declaration of conformity and with a CE mark (in accordance with the Machinery Directive).

Directives	
EC Directives	06/42/EC (Machinery) (partially observed) 2014/30/EC (EMC) 2014/35/EC (Low voltage)
Harmonized standards	
EN ISO 12100:2010	Safety of Machinery – General Principles for Design Risk Assessment and Risk Reduction



## 5 Identification

### 5.1 Manufacturer, Ordering of Spares and Customer Service

Opsytec Dr. Gröbel GmbH  
 Am Hardtwald 6-8  
 D – 76275 Ettlingen  
 Tel.: +49(0)7243 / 9 47 83-50  
 Fax: +49(0)7243 / 9 47 83-65  
 info@opsytec.de  
 www.opsytec.com

### 5.2 Change History



We reserve the right to make changes in content. Opsytec Dr. Gröbel GmbH is not liable for any errors in this documentation. No liability shall be accepted for indirect damages arising from the delivery or use of this documentation, in as far as this is legally permissible.

Version	Changed by	Date	Change
3.0.0	Paravia	27.08.2020	UV-MAT and PC control added

### 5.3 Copyright



Opsytec Dr. Gröbel GmbH shall retain the copyright for these operating manual. The operating manual is intended for the owner/operator and his personnel.

#### **Copyright in accordance with DIN ISO 16016:**

Reproduction and copying of this document, use and disclosure of its contents are prohibited unless expressly authorized.

Non-compliance may result in a claim for damages. All rights reserved in case of registration of patent, utility patent, or design patent.

Contraventions may be subject to prosecution.

### 5.4 Identification of the Device

For internal use at customer site:

Description of machinery:	Irradiation chamber BSH-02
Year of construction:	.....
Machine No.	.....
Project no.	.....

## 5.5 Intended Use

The irradiation chamber is a controlled radiation-source for different UV applications like

- UVC irradiation & cleaning
- Accelerated aging of plastics and similar materials with UVC
- Curing / Hardening

It can be equipped with ozone-free or ozone generating UVC lamps.

The system is exclusively intended for industrial use. It is forbidden to use the devices in explosive environments or for general illumination.

- Installation, commissioning, operation, maintenance and service works must solely be performed by trained and educated, qualified personnel, which observes all safety regulations and standards.
- Responsibility: Damages resulting from unintentional or unauthorized interventions terminate every right, to raise warranty or liability claims against the manufacturer.
- Guarantee exclusion: The use of any non-original parts voids the guarantee.
- Environmental protection: Defect parts, which may contain environmentally harmful substances, must be disposed of accordingly.
- During the operation a high-energy UV and/or visible radiation is generated.
- Ozone may be produced in the course of operation.
- Operation is only permitted in a dry environment. The installation is horizontal.
- Only suitable for the operation in closed rooms.
- Prior to opening, the system must be disconnected from the voltage and it must be checked that there is no voltage present.
- Wear gloves for maintenance, cleaning and exchanging the lamps and optical components.
- The system must not be cleaned when in operation.
- The door must not be opened during irradiation. The front door is monitored. Should it be opened during the irradiation, the UV lamps will automatically switch off. Since this is done with a slight delay, the user will possibly be briefly exposed to UV radiation.
- Any other use than the above mentioned, results in damages to the product. Furthermore, it is associated with risks such as short circuits, fire and electric shocks. The entire device must not be changed and/or modified! The safety notes must be observed at all times.

	⚠ CAUTION
	<p><b>System may fall down! Device damaging and personal injuries are possible</b></p> <ul style="list-style-type: none"> <li>• Always carry the system with two persons.</li> </ul>

## 5.6 Foreseeable Misuse

The following is considered foreseeable misuse:

- Operation of the device without safety devices and equipment.
- Activities of uninstructed personnel on the device.
- Non-compliance with the operating instructions of the owner/operator.
- Ignoring of the operating manual.
- Any other use outside the intended specified use.

## **5.7 Legal Information**

### **5.7.1 Limitation of Liability**

All the information in this manual was compiled with consideration of the currently valid standards and regulations, of the technical standard and our long-standing knowledge and experience.

The manufacturer shall not be liable for damage in the event that:

- This manual is ignored,
- The device is improperly used,
- Untrained personnel is deployed,
- Untrained personnel operates the machine incorrectly,
- Unauthorized modifications are made,
- Technical changes are made,
- Non-approved spare parts are used.

We shall not be liable for common faults of the device caused by power outage or failure of the control system.

The actual scope of delivery may be different than the explanations and pictures in this manual in case of special versions, when additional options are ordered or due to the latest technical changes.

The obligations agreed in the delivery contract, as well as the legal requirements valid at the time the contract was concluded shall apply.

### **5.7.2 Declaration of conformity**

The declaration of conformity is in the annex or can be requested from the manufacturer.

### **5.7.3 Warranty Terms**

The warranty terms and guarantee conditions are governed by the German Civil Code (BGB). The warranty period is one year unless otherwise agreed in the purchase documents.

## 6 General

### 6.1 Information about this Manual

This manual intends to make handling of this system and its components safe and efficient. The manual is part of the system and must be kept in its immediate vicinity where it is accessible for the personnel at any time.

This documentation contains the necessary information for the intended use of the described system. It is intended for technically qualified personnel who have been especially trained for operation, laboratory use, quality assurance, service and repair.

The personnel must have read this manual carefully and understood its content before commencing any work. The basic condition for safe working is observation of all stated safety information and operating instructions in this manual.

Knowledge and technically faultless implementation of the instructions, safety requirements, safety information and warnings are a condition for safety in operation, service and repair. Only qualified personnel has the required professional knowledge to apply the safety requirements, safety information and warnings stated in this operating manual in a general way correctly in a concrete situation.

In addition, the local accident prevention regulations and general safety regulations apply for the area of application of the system.

Illustrations in this manual serve the purpose of general understanding; they may differ from the actual version.

Apart from this manual the instructions for the installed components included in the appendix apply.

This operating manual cannot take any possible case of maintenance into account. If you need further information or if special problems occur that are not treated extensively enough in this manual please request the required information from the manufacturer.



For a simple description, the above mentioned components are collectively referred to as system.

## 6.2 Information about the Symbols

### 6.2.1 Safety Instructions

In this manual, safety information is indicated by means of symbols. Safety information is preceded by signal words that indicate the scope of risk.

To avoid accidents and damage to persons or property, always follow the information and act prudently.

Throughout the text, you will find the following pictograms with the following meanings:

	<b>⚠ DANGER</b>
	<p><b>Imminent danger</b> Possible consequences: death or most serious injuries.</p> <ul style="list-style-type: none"> <li>• Prevention</li> </ul>

	<b>⚠ WARNING</b>
	<p><b>Dangerous Situation</b> Possible consequences: death or most serious injuries.</p> <ul style="list-style-type: none"> <li>• Prevention</li> </ul>

	<b>⚠ CAUTION</b>
	<p><b>Possible Situation</b> Possible consequences: slight or minor injuries. Sometimes also used for warning of material damage.</p> <ul style="list-style-type: none"> <li>• Prevention</li> </ul>



#### Note

Information for use or useful important information

### 6.2.2 Prohibition Signs



General "Prohibited-sign"

### 6.2.3 Warning Signs



Warning of optical radiation  
(such as UV, IR, or visible radiation)



Warning of hot surface!



Warning of electricity!

### 6.2.4 Attention



Wear eye protection!



Opaque eye protection must be worn!



Disconnect mains plug from electrical outlet!



Disconnect before carrying out maintenance or repair!



Use hand protection!



Wear foot protection!



Refer to instruction manual/booklet

### 6.2.5 Fire Protection Sign



Extinguishing hose



Fire extinguisher

### 6.2.6 Rescue Sign



Emergency exit: marking of all emergency exits with this symbol

### 6.2.7 Optional functions

\* Optional functions, not available for every system



### 6.3 Owner/Operator Information

The System is used in the commercial sector. The owner/operator of the system is therefore subject to the legal obligations concerning work safety.

In addition to the safety information in this manual, the generally applicable regulations valid for the application area of the system concerning safety, prevention of accidents and for protection of the environment must be noted and complied with.

The following applies in particular:

The owner/operator must acquire information about the valid occupational health and safety information and in a risk assessment determine additional hazards incurred due to the special operating conditions at the location of use of the system. He must implement these in the form of operating instructions for operation of the system and specifically for the individual work stations.

The owner/operator is obliged to check during the entire lifetime of the system whether the operating instructions that he generated comply with the current status of the regulations and update them if necessary.

The owner/operator must assign and define the responsibilities for installation, operation, rectification of faults, service and cleaning unambiguously.

The owner/operator must ensure that all personnel dealing with the system have read and understood this manual. Furthermore, he is obliged to provide personnel training in regular intervals and provide information about risks.

The owner/operator must provide the required personal protective equipment for his personnel. Furthermore, the owner/operator is responsible that the system is always in faultless technical condition. To ensure this, the service intervals specified in this manual and in the technical documents for the individual systems must be observed and all safety installations must be checked regularly for function and completeness.

The owner/operator must have all safety devices checked regularly for function and completeness.

The owner/operator must ensure that the operating personnel have knowledge about first aid measures and local rescue installations.

## 6.4 Personnel Requirements

### 6.4.1 Qualifications

	⚠ WARNING
	<p><b>Risk of injury when personnel are insufficiently qualified!</b></p> <p>If unqualified personnel carries out work on the system or stays in the danger area of the system risks arise that may cause severe injuries and serious material damage.</p> <ul style="list-style-type: none"> <li>• Have all activities carried out only by personnel qualified for the activity.</li> <li>• Keep unqualified personnel away from the danger area.</li> </ul>

	⚠ WARNING
	<p><b>Risk of injury when touching live parts or hot surfaces</b></p> <p>Generally, low voltage devices like this system can have dangerous live parts and hot surfaces. All works for transportation, installation, commissioning, start-up and maintenance must be performed by respectively trained and responsible, qualified personnel (in accordance with EN 50110-1 (VDE 0105-100); IEC 60364). Inappropriate behavior can lead to serious injuries or damages.</p> <p>During the irradiation the LAMP temperature may rise up to approx. 60° C. Caution - risk of burns.</p>

Below, this manual lists the qualifications of the personnel for the various areas of activity:

#### 6.4.2 Electrically skilled person

Due to their professional training, knowledge and experience and knowledge of the relevant standards and regulations, electrically skilled persons are able to carry out work on electrical systems and to recognize and avoid risks independently.

Electrically skilled persons are specially trained for the work environment where they are working and they know the relevant standards and regulations. Electrically skilled persons must fulfil the requirements of the valid legal regulations for accident prevention.

#### 6.4.3 Qualified person

Qualified persons are trained or can be trained by Opsytec Dr. Gröbel GmbH in extended operation and parameterization of the system as well as in execution of preventive service work.

In addition, due to their technical training, knowledge and experience and knowledge of the relevant standards and regulations, they are able to carry out work they have been assigned and to recognize and avoid possible risks independently.

#### **6.4.4 Operators**

Operators use and operate the system in the scope of the intended use. They are trained by the owner/operator in the work assigned to them and informed about possible risks.

#### **6.4.5 Training and Qualification of Personnel**

In regular instructions and training, operating personnel must be informed about the special risks when working with and handling the system.

The instruction and training should have the following content:

- Hazards when working with the system in normal operation.

- Hazards in connection with service, repair and cleaning activities.

- Conduct to minimize consequences of accidents.

- Conduct in case of accidents.

- Rescue of injured persons.

- Working without personal protective equipment may cause health damage. The company supervisor is instructed to pay attention that personnel are wearing personal protective equipment.

- Particular hazards when working on the electrical system.

Instruction and training must be carried out in regular intervals by the owner/operator. For better tracking, execution of instruction and training should be recorded.

## **6.5 Personal Protective Equipment**

The purpose of personal protective equipment is to protect the personnel from risks that might affect his safety or health when working.

When executing various activities on and with the system, the personnel must wear personal protective equipment. This will be pointed out again in the individual chapters of this manual. Below, personal protective equipment is explained:

### **6.5.1 Protective Gloves**

Protective gloves are used to protect hands from visible and invisible radiation, friction, abrasion, stabs and deep injuries.

### **6.5.2 Protective Goggles**

Protective goggles are used to protect eyes from intense visible and invisible radiation.

### **6.5.3 Safety Boots**

Safety boots are used as protection from heavy parts falling down and slipping on slippery surfaces.

## 7 Safety Information and Residual Risk





### 7.1 General



The system is state-of-the-art and has been built in compliance with recognized safety regulations. Nonetheless, its use may constitute risks for life and limb of the operating and repair personnel (service personnel) or third parties or impairments to the machine. Operate the system only when its safety devices are in faultless condition. Disruptions that impair its safety must be rectified at once.



The following safety information must be strictly observed to prevent damage to the machine and personal injury!

	<b>⚠ WARNING</b>
	<p><b>Risk of injury when personnel do not read the operation manual!</b> Prior to commissioning and operation, read the operation manual completely. Read all safety information and instructions. Negligence concerning safety information and instructions may cause electric shock and/or severe injuries.</p>

## 7.2 Safety Information Concerning Normal Operation

	<p style="text-align: center;"><b>⚠ DANGER</b></p> <p><b>Danger to life</b>          Danger to life occurs when the system is operated with defective or absent safety devices.</p> <ul style="list-style-type: none"> <li>The system should be operated only when all protective devices and safety-related installations are present and in working condition. The operator of the machine is obliged to check the safety devices for proper function regularly before production is started.</li> </ul>
	<p style="text-align: center;"><b>⚠ DANGER</b></p> <p><b>Imminent danger by Ozone</b>          When using ozone-generating lamps, the exhaust air can be enriched with ozone. Ozone is harmful to health when inhaled in high concentrations through the lungs and long periods of time. Always avoid inhaling ozone.</p> <p>A suitable drainage and treatment of waste air must be ensured so that the permissible ozone workplace concentration (MAK value) is not exceeded.</p>
	<p style="text-align: center;"><b>⚠ WARNING</b></p> <p><b>Risk of Fire!</b>          An extremely high irradiance, which can ignite combustible materials in cases of permanent radiation, is reached inside at the top of the irradiation chamber. Do not place any combustible material direct under the LAMPs and observe the irradiation time and the material temperature.</p>
	<p style="text-align: center;"><b>⚠ WARNING</b></p> <p><b>Risk of injury when touching hot surfaces</b>          During the irradiation the LAMP temperature may rise up to approx. 60° C. Caution - risk of burns.</p>

 CAUTION	
	<p><b>Risk of Damage</b></p> <ul style="list-style-type: none"> <li>• Skin fat and dirt are absorbent in the UV and visible spectral range.</li> <li>• Avoid fingerprints on the optically active sensor surface. If necessary, the components must be cleaned carefully with Isopropyl.</li> <li>• Use safety goggles and gloves when working inside sample room of the BSH-02 irradiation chamber.</li> </ul>

 CAUTION	
	<p><b>Risk of Damage</b></p> <p>The system warms up during operation.</p> <ul style="list-style-type: none"> <li>• Make sure that there is an adequate air circulation at the installation site.</li> <li>• Air vents in the device housing must not be covered.</li> <li>• Provide enough fresh air for cooling the BSH-02. The access of the air is at the bottom of the device. Place the lamp on a hard surface.</li> <li>• Also provide a good air escape at the top of the lamp. Don't mount the lamp in a closed box to avoid a cooling short-circuit.</li> <li>• Operate the lamp only with chassis completely closed. With chassis open the cooling has no effect.</li> </ul>

For activities in normal operation a brightness of at least 300 Lux must be provided.



Access to the machine is only permitted for operating personnel and instructed personnel.

Operation the machine is only permitted for instructed operating personnel.

Removing or disabling protective devices is not allowed during operation of the system.

If any protective devices or equipment fail or have become faulty, this must be reported to the operations supervisor immediately. He will decide about further procedure.

### 7.3 Radiation Safety

 <b>WARNING</b>	
	<p><b>Risk of eye injury</b> <b>UV-radiation is harmful! Always wear suitable safety glasses. Avoid direct exposition.</b></p> <p>This product is equipped with UV and visible high intensity Lamps. There is a risk of photo-chemical or thermal damage of the eye, retinal damage of the eye and erythema. The operating staff is to be trained appropriately.</p> <p>For protection of the operating staff, do not look into the UV light and do not expose the skin continuously to UV radiation.</p> <p>Note: In case of a malfunction, the UV light can be switched on, even though the status or the trigger output does not signalize this. Before working with the device, please check that the lamps are switched off.</p>





## 7.4 Safety Information Concerning Service and Repair Work



	<b>⚠ DANGER</b>
	<p><b>Imminent danger by Ozone</b></p> <p>When using ozone-generating lamps, the exhaust air can be enriched with ozone. Ozone is harmful to health when inhaled in high concentrations through the lungs and long periods of time. Always avoid inhaling ozone.</p> <p>A suitable drainage and treatment of waste air must be ensured so that the permissible ozone workplace concentration (MAK value) is not exceeded.</p>

	<b>⚠ WARNING</b>
	<p><b>Risk of injury! High Weight!</b></p> <p>Always carry the system with two persons.</p>

	<b>⚠ WARNING</b>
	<p><b>Risk of injury when touching live parts</b></p> <p>Before opening the system, disconnect all components from the supply voltage and check that no voltage is present.</p>

	<b>⚠ CAUTION</b>
	<p><b>Risk of Damage</b></p> <ul style="list-style-type: none"> <li>• Switch off the control unit prior to connecting / disconnecting accessories. Due to the operating voltage of the unit, the accessories can get damaged.</li> <li>• Unplugging &amp; plugging of signal cables during the operation is strictly forbidden!</li> </ul>

	<b>⚠ CAUTION</b>
	<p><b>Risk of Damage</b></p> <ul style="list-style-type: none"> <li>• Skin fat and dirt are absorbent in the UV and visible spectral range.</li> <li>• Avoid fingerprints on the optically components, sensor surfaces, Lamps and reflectors. If necessary, the components must be cleaned carefully with Isopropyl.</li> </ul>

 CAUTION	
	<p><b>Risk of Damage</b></p> <p>The system warms up during operation.</p> <ul style="list-style-type: none"><li>• Make sure that there is an adequate air circulation at the installation site.</li><li>• Air vents in the device housing must not be covered.</li><li>• Provide enough fresh air for cooling the BSH-02. The access of the air is at the bottom of the device. Place the lamp on a hard surface.</li><li>• Also provide a good air escape at the top of the lamp. Don't mount the lamp in a closed box to avoid a cooling short-circuit.</li><li>• Operate the lamp only with chassis completely closed. With chassis open the cooling has no effect.</li></ul>

Service, repair and cleaning work must only be carried out by authorized and specifically trained professionals. The system must be power-free and secured before major work is carried out (including cleaning).

Carry out the prescribed setting, service and inspection work according to schedule. If you need further information or if special problems occur that are not treated extensively enough in this manual please request the required information from the manufacturer.

Only specialized electricians may perform work on electrical equipment.

Safety devices may only be removed during service and repairs, if the system was previously switched off and brought into a safe condition.

For service and maintenance work, important safety installations may not be functional. Work of this kind therefore requires special caution.

## 8 System Description

The irradiation chamber BSH-02 is a high-powered UVC chamber with superior irradiance of 85 mW/cm<sup>2</sup>. Like all BS irradiation chambers, the BSH-02 offers time- or dose-controlled irradiation of samples with UV light. The chamber is fully equipped with ozone-free UVC amalgam lamps with a total lamp power of 750 W. Compared to our standard BS series, the BSH-02 offers irradiance that is 750% higher. Thus, the irradiance is high enough for high-energy applications or UV curing.

The BSH-02 has compact outer dimensions and the interior irradiation chamber has a base area of 46 x 32 cm and a height of 25 cm. The sample chamber operating temperature is about 45°C so that thermal damage to the specimen is minimized. Due to the high uniformity of the irradiation, the samples may be positioned in any order.

The irradiation control UV-MAT can control two spectral ranges separately and achieves a constant dose independent of lamp aging, contamination or temperature. The dose is measured with calibrated sensors. For this purpose, the sensor already contains an extremely precise analog-digital converter and a temperature sensor. The integrated diffuser ensures the required cosine correction. Excellent long-term stability is achieved through the use of appropriate materials. The sensors are calibrated with traceability to PTB (Physikalisch Technische Bundesanstalt, the German national test authority); after being calibrated, they are supplied with a factory calibration certificate. The memory in the sensor contains all sensor identifications and the calibration history.

The UV-MAT can optionally be controlled by a PC. This allows multi-stage irradiation and documentation of the irradiation.

The components at a glance:

(Image similar)

Pos.	Designation	Pos.	Designation
1	Irradiation chamber	2	Front door
3	Mains switch	4	Control lamp (lamps ON)
5	Lamps	6	Sample plane
7	Sensor holder	8	Cable feedthrough
9	Door contact		



BSH-02 chambers that are designed for ozone generating lamps have connectors for air exhaust.



Rear view and ventilation concept:

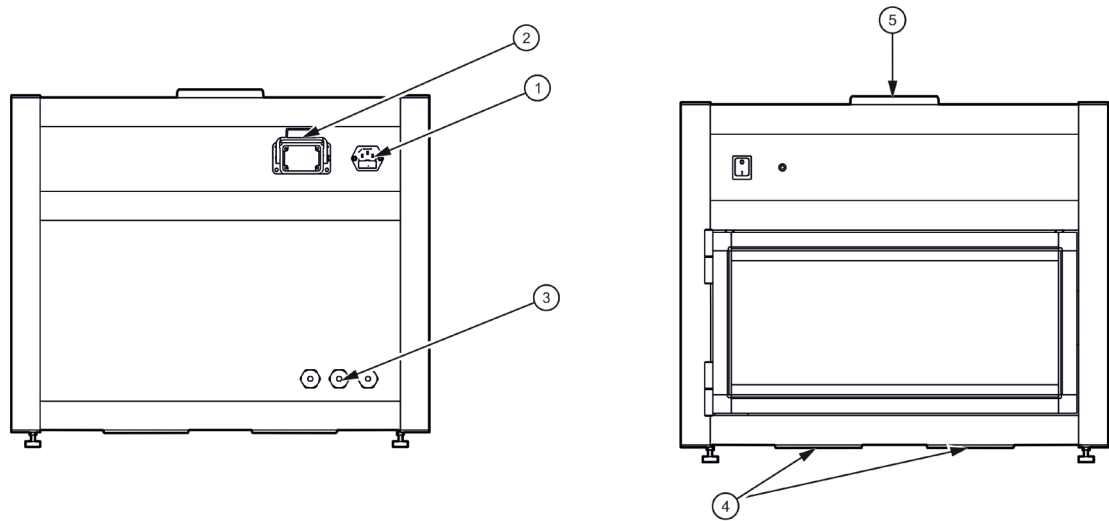

Pos.	Designation	Pos.	Designation
1	Mains connector	2	Connector for UV-MAT
3	Cable feedthrough	4	Air inlet for samples
5	Air outlets		



The signal lamps on the front of the irradiation system also show the status of the lamp groups.

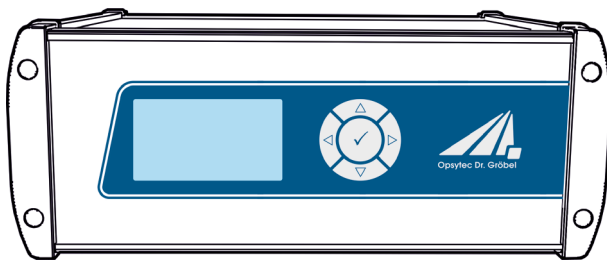

(1)

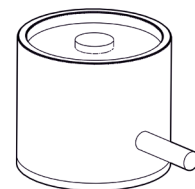

(2)

Pos.	Designation	Pos.	Designation
1	UV-Mat	2	Sensor

The UV-MAT unit contains the power supply, the microcontroller system with display and keyboard and the output controls. The sensor is connected to the backside of the UV-MAT unit.

The sensors are adapted to the lamps, meaning UVA+ sensor for UVA lamps for example. The sensors are cosine corrected. Due to the excellent cosine correction it is possible to measure from a side position.

**The following components are delivered:**

- Irradiation chamber
- UV-Mat
- Sensor
- Power line cable
- This documentation
- Optional:
  - inert box
  - Lamps
  - PC interface / programming interface / USB
  - Connecting cable for the communication



For a simple description, the above mentioned components are collectively referred to as system.

**The following components are required by the customer:**

- none

## 9 Commissioning

- Unpack all components and remove the packaging materials.

	<b>⚠ WARNING</b>
	<b>Risk of injury! High Weight!</b> Always carry the system with two persons.



BSH-02 chambers that are designed for ozone generating lamps have connectors for air exhaust.

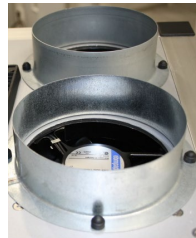

- When bought ozone generating lamps: The BSH-02 must be connected to a ventilation system with two exhaust pipes because ozone is produced in the course of operation. Use flexible aluminum plumbing.
- When using ozone-free lamps the BSH-02 is equipped with classical fan covers. Do not install ozone generating lamps
- The BSH-02 is supplied with unmounted UV lamps.



- Open the front door and insert the lamps into the lamp sockets. This is done by pressing the lamps into the folders and clipping on the electrical connectors.

- The BSH-02 uses a ventilation system. Make sure that the air inlets and outlets are not covered.
- Connect the UV-MAT with the irradiation chamber using supplied cable.

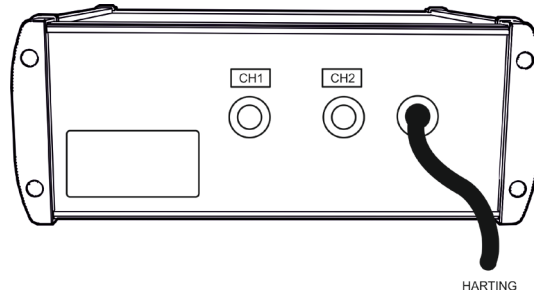

(Image similar)

- Connect the sensor:
  - Mount the sensor in the left-hand sensor holder inside the irradiation chamber.
  - Remove sensor caps.
  - Route the sensor cable through cable feedthrough in the rear side of the irradiation chamber.
  - Connect the sensor with the UV-MAT
- Connect the irradiation chamber with mains voltage.
- Switch on the system by means of the switch on the front of the chamber.
- BSH-02 is commonly completely operated by UV-MAT.

### 9.1 Installing and replacing a lamp

The useful life of UV amalgam lamps depends on the system design and the mode of operation (ON-OFF switching cycles, cooling, and pollution).

Frequent switching the BSH-02 on / off can lead to a significantly reduced useful lifetime.

The UV lamp needs to be replaced when it no longer ignites, or the performance is no longer achieved.

Commonly your BSH-02 is equipped with a UVMAT.

	<b>⚠ WARNING</b>
	<p>Before opening to change the lamps or repair some electronics the chamber or parts the control electronics, have to be disconnected from the power supply and the absence of voltage is to be checked.</p>

The lamp replacement is easy through the front door of the BSH-02. Proceed as follows:



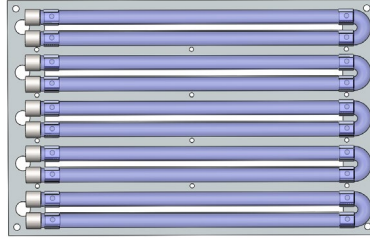

1. Disconnect the system from the power supply and check that no voltage is present.
2. Allow the lamps to cool.
3. Open the front door and insert the lamps into the lamp sockets. This is done by pressing the lamps into the folders and clipping on the electrical connectors.

Skin oils and dirt are absorbed in the UV spectral range. Fingerprints on the reflectors should, therefore, be avoided. Fingerprints on the light emitter must be thoroughly cleaned with acetone and isopropyl alcohol since otherwise the emitters can overheat locally.

4. Insert the new lamps. Replace the lamps only with new ones of the same type and pay attention to the correct installation of the lamp socket.

## 10 Commissioning and Use of inter box\*

### If your chamber is equipped with an inert box:

Unpack inert box and clean front window with ISOPROPANOL alcohol.

Air-inlet and air-outlet can be changed depending on customer needs.

Pull the connecting hoses for the N2 input and N2 output through the rear openings of the irradiation chamber.

Attach the connecting hoses to the inert box.

Open the inert box with the four screws on the top and place the parts to be irradiated in the inert box.

Place the inert box in the irradiation chamber. Flush inert box until output gas oxygen concentration is below required limit. As an alternative: Flush inert box for several minutes.

Irradiate!

After irradiation, proceed in reverse order.

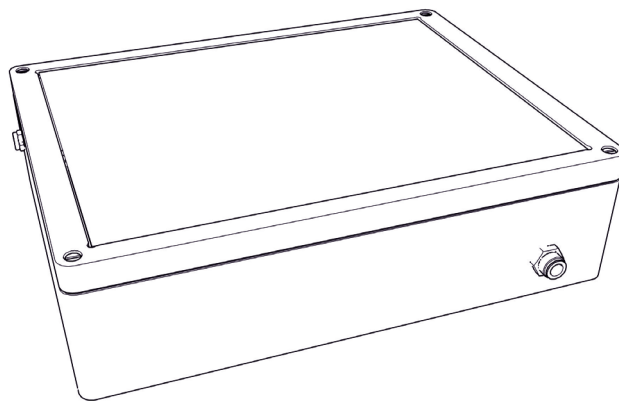

(Image similar)

	<b>⚠ WARNING</b>
	<b>Risk of injury!</b> Do not evacuate the inter box. Inert box is not made for evacuation.

## 11 Operating

The irradiation chamber is switched on with the power switch on the front. According to your included option the operation may vary. Options are:

- Operation mode switch
- Sensors and sensor holder
- Lamp dimming
- Timer
- Dose controller UV-MAT
- Inert box

### In general:

Open the front door of the irradiation chamber and place the objects to be irradiated in the irradiation chamber.

Use safety goggles and gloves when working with the BSH-02 irradiation chamber.



Make sure that the built-in sensor is not covered for dose-controlled radiation.

Close the front door of the irradiation chamber, otherwise the UV lamps won't turn on.

Start the irradiation by UV-MAT (see next chapter).

At the end of the exposure the lamps will automatically turn off. The lamp temperature can reach approximately 100-150° C during irradiation. Open the front door of the irradiation chamber and carefully remove the irradiated objects.

Don't forget to switch off irradiation chamber.

 <b>WARNING</b>	
	<p><b>Risk of burns!</b></p> <p>During the irradiation the lamp temperature may rise up to approx. 150° C.</p> <p>Caution - risk of burns.</p> <p>The front door is monitored. Should it be opened during the irradiation, the UV lamps will automatically switch off. Since this is done with a slight delay, the user will possibly be briefly exposed to UV radiation.</p>



The signal lamps on the front of the irradiation system also show the status of the lamp groups.

## 12 UV-MAT operation

The UV-MAT is operated via five keys. These keys are arranged in the front, right next to the display. The keys and the function configuration are shown below:

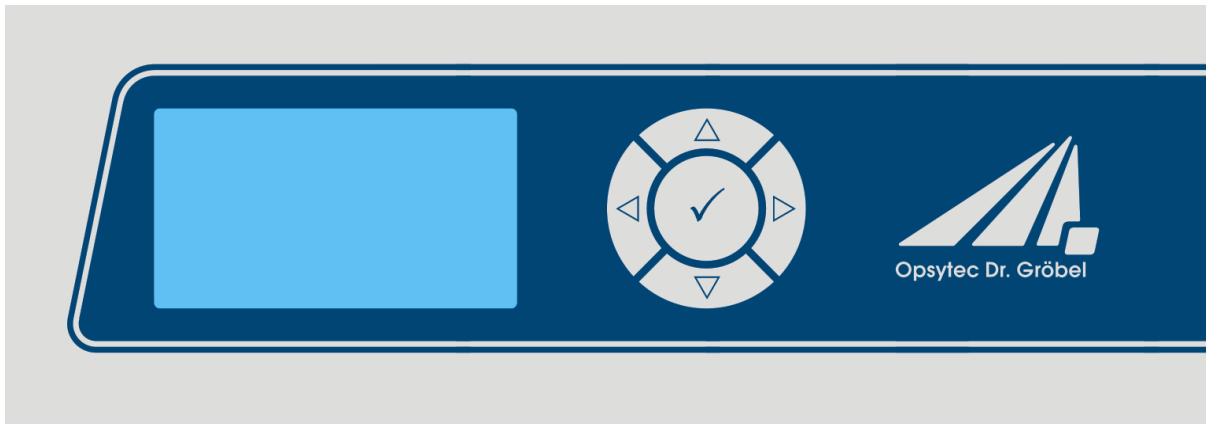

Key	Function
▽	Down
△	Up
◁	Left
▷	Right
✓	Confirm / OK

Initially after starting the device, the logo appears in the display for 2 seconds.



Now the device is in standby and is displayed in the main menu.

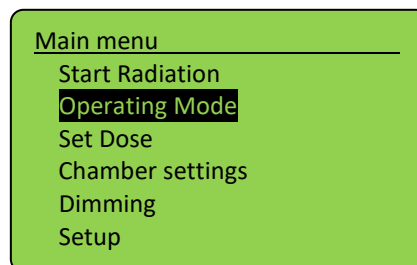

The menu items in the main menu depend upon the settings, i.e. the menu items “Dimming” and “Irradiation time” are only displayed, when the respective mode has been selected.

In the main menu and all other menus, select the active menu item via the keys ▽ and △. By clicking ✓ you confirm the selected menu item. With ◁ you return to the previous menu without adopting the changes.

The selected menu item is displayed on a black background and inverted.

UV-MAT offers three operation modes:

- Timer
- Slave
- Remote (via programming interface, USB)

The menu items depend on the settings. For example, the menu item "Irradiation time" is only displayed if the corresponding timer mode has been selected.

## 12.1 Switching on

Switch on the control unit at the front switch. After starting the device, the logo appears on the display followed by a short self-test.

The device is then in standby and the menu is displayed.

## 12.2 Switching off

Switch off the LED system at the front switch.



The operating mode and the set power are saved permanently. After a restart, the last operating mode is selected (exception: settings).

### 12.2.1 Operation Mode

Select operating mode the select dose controlled or time controlled irradiation.

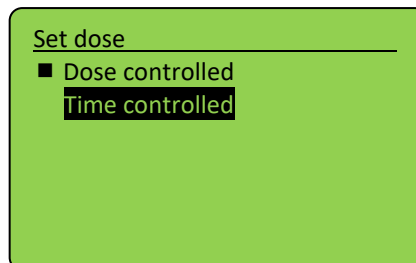

Confirm by with ✓ or ▷. With ◁ you can cancel your input and go back to main menu.



In dose controlled mode the irradiation time is automatically controlled and stops if the desired dose is reached. Note a sensor must be connected therefore.



In time controlled mode the irradiation time controlled by a timer only. On the display only the irradiation time is displayed. A sensor is not necessary.

The Irradiation time is selectable for both channels individually.

## 12.2.2 Start / Stop Radiation

Start an irradiation by selecting “Start Radiation” and press ✓.



The ballasts preheat the lamp filaments up to approx. 15 seconds. The lamps ignite at this time and then work on high power (warm-up time). A constant irradiation is reached after about 5 min.

In time controlled operation mode the current irradiation time and end time are displayed in the form DD:HH:MM:SS.

In dose controlled operation mode the current irradiance in  $\text{mW}/\text{cm}^2$ , the actual irradiation time, the current dose (Is:) and the target dose (Set:) are displayed:

Ch1	Ch2	1&2	DIM	1&2	⏻	⏹
Is:	000:00:00:50					
CH1:	000:00:00:50					
CH2:	000:00:00:50					
UVA:	5.05 $\text{mW}/\text{cm}^2$					
UVB:	2.00 $\text{mW}/\text{cm}^2$					

Time controlled

Ch1	Ch2	1&2	DIM	1&2	⏻	⏹
UV-A:	5.05 $\text{mW}/\text{cm}^2$					
Time:	00 : 00 : 00 : 50					
Is:	0.002507 $\text{J}/\text{cm}^2$					
Set:	10.0000 $\text{J}/\text{cm}^2$					

dose controlled



Use to ◀ and ▶ keys to switch channel screens.



$\text{mW}/\text{cm}^2$  and  $\text{J}/\text{cm}^2$  are automatically calculated.



Dimming level can be changed during active irradiation with ▲ and ▼ keys. If CH1 or CH2 is selected then the corresponding lamp group is dimmed. In case of 1&2 or DIM both lamp groups are dimmed.

In the dimming screen the current lamp power is visible:

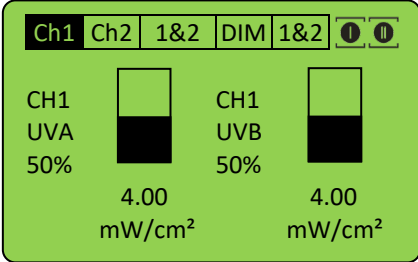

Stop an irradiation by pressing ✓ for at least 2 seconds.

### 12.2.3 Timer mode

In the menu "Irradiation Time" you can set the irradiation time for the timer. Therefore select menu item "Set time". If "Set time" is not displayed, please choose "Time controlled" in menu "Operation Mode" first.

The irradiation time can be set for CH1 and CH2 together or individually. Select the time you like to change.

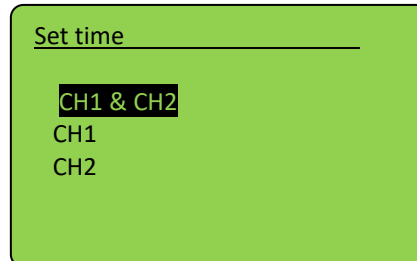

Now you can select the decimal with the keys ◀ or ▶ and with the keys ▲ or ▼ you can set the time to the desired value. Confirm with OK (✓) to return to the main menu.

In timer mode you can set the duration of irradiation:

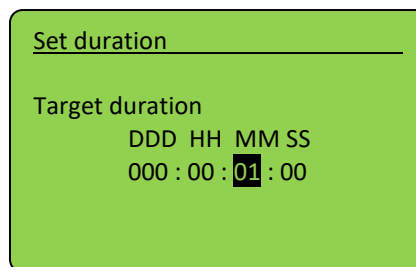

The maximum duration is 999 days, 23 hours, 59 minutes and 59 seconds.

The irradiation time can be set different for both channels.

With the keys ▼ and ▲ the power can be modified during the exposure.

In time controlled mode the irradiation time controlled by a timer only. On the display the irradiation time and, if a sensor is connected the irradiance, is displayed. A sensor is not necessary for timer mode.

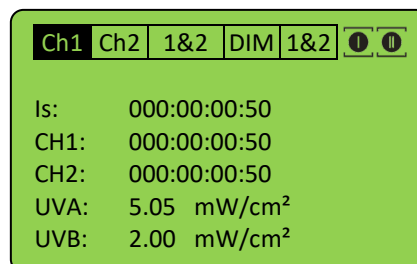



### 12.3 Dose controlled mode

Select operation mode dose controlled. Confirm by with ✓ or ▷. With ◁ you can cancel your input and go back to main menu.



In dose controlled mode the irradiation time is automatically controlled and stops if the desired dose is reached. Note a sensor must be connected therefore.

Set the target dose for an irradiation in the menu “Set dose” and select the channel / sensors first:

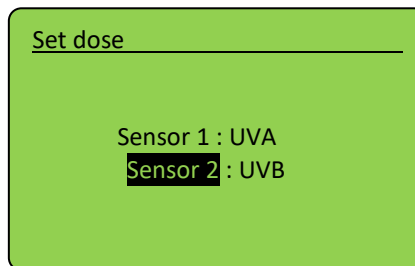

Now, select the dose:

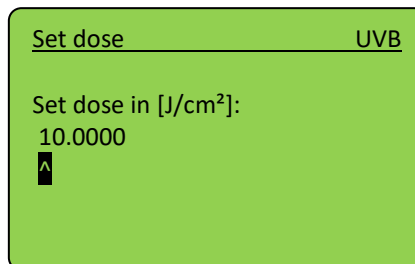

Use the ◁ key to add a digit.

Use △ and ▽ keys to change value and confirm with ✓.

Return to main menu and start an irradiation by selecting “Start Radiation”.

In dose controlled operation mode the current irradiance in mW/cm<sup>2</sup>, the actual irradiation time, the current dose (Is:) and the target dose (Set:) are displayed:

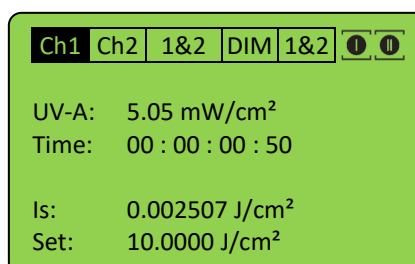



mW/cm<sup>2</sup> and J/cm<sup>2</sup> are automatically calculated.

Stop an irradiation by pressing ✓ for at least 2 seconds.

## 12.4 Dimming

Select dimming to adjust lamp output. Therefore go to menu "Dimming", select channel to be dimmed:

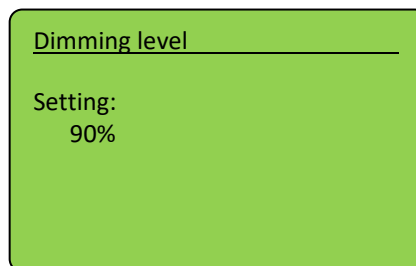

Use △ and ▽ keys to set desired value. Confirm with ✓.



Dimming level can be changed during active irradiation with △ and ▽ keys.

## 12.5 Setup of internal settings

### 12.6 Settings, system behavior

Using this menu you can set the system settings.

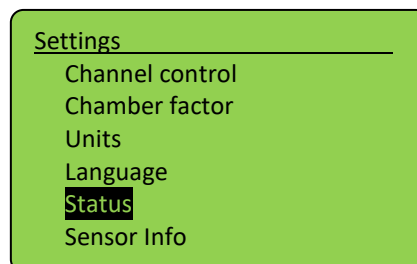

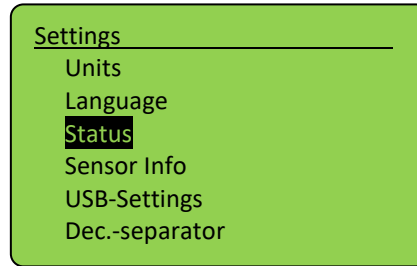

### 12.6.1 Channel control

The system has two lamp groups (even and odd numbered lamps). Always use the lamps alternately when using two different types. Use channel control to select mode

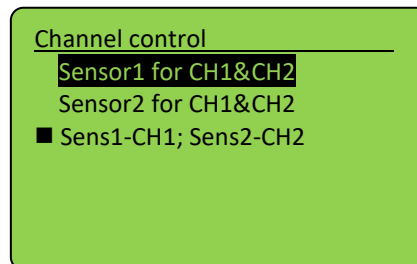

#### Sensor1 for CH1&CH2:

All lamp groups controlled by the dose set for sensor connected to input Sensor 1

#### Sensor2 for CH1&CH2:

All lamp groups controlled by the dose set for sensor connected to input Sensor 2

#### Sens1-CH1; Sens2-CH2:

Odd-numbered lamps controlled by Sensor 1, even-numbered lamps controlled by Sensor 2. The lamp groups are controlled by each sensor using this mode. This setting makes sense, while other setting may be for special applications.

Note, that the channel control is displayed during irradiation in the upper right corner. Here the icons have e.g. the following meaning:

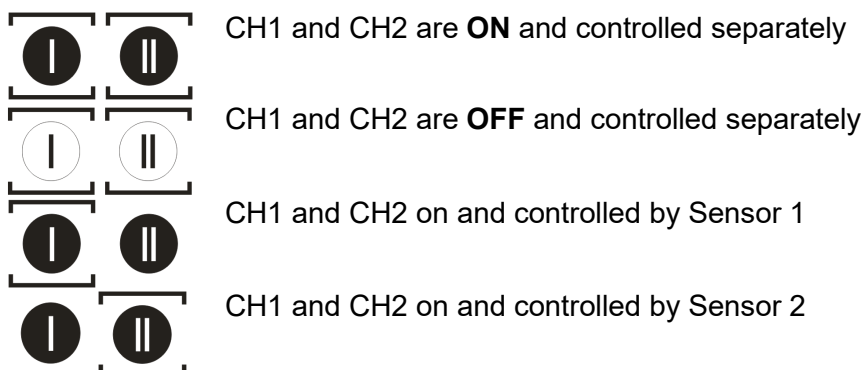

The signal lamps on the front of the irradiation system also show the status of the lamp groups.

### 12.6.2 Chamber factor

In this submenu the sensor specific adjustments are placed. It is possible to do the sensor calibration and set the upper and lower limits. In all three submenu points you have to decide first for which sensor port you want to do the adjustment, if Your UV-Mat version is capable of more than one sensor.

The sensor factor is used to calculate and output the irradiance at a different position (than at the sensor position). This means that the irradiance displayed is the same even when measuring at the lateral sensor position.

The sensor factor has already been determined and preset by the manufacturer. See the technical documentation in the appendix.



This setting should be checked for different sample sizes / sample heights. The initial setting was made in the middle, approx. 35 mm above the sample level (chamber bottom).

Example:

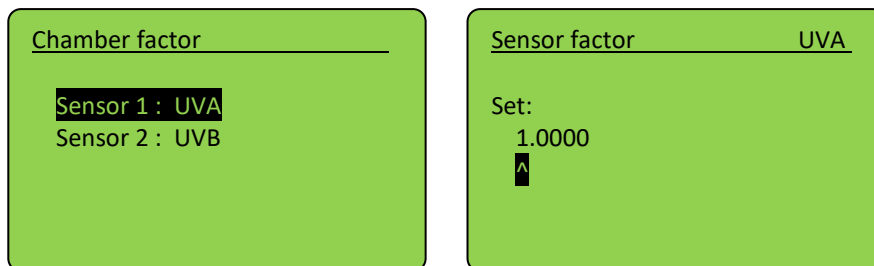

If you want to use the irradiance at any position, proceed as follows:

- Set the sensor factor to: 1.0000
- Measure the irradiance at (any) position 1.
- Measure the irradiance at the sensor position.
- Divide the irradiance at position 1 by the irradiance at the sensor position. The result is the sensor factor.
- Adjust the sensor factor.
- Repeat the setting if you use several sensors / lamp groups.



Use the button ◀ to add a digit.

Navigate with ◀, ▶ and set value with ▲, ▼. Confirm with ✓ to go back to setup menu.

### 12.6.3 Units

Unit in which the measured values of the sensors are displayed. This is a setting for the sensor that applies to the measured channel (including dose).

Irradiance

- $\text{mW/cm}^2 \Rightarrow \text{mJ/cm}^2$
- $\text{W/m}^2 \Rightarrow \text{J/m}^2$
- $\mu\text{W/cm}^2 \Rightarrow \mu\text{J/cm}^2$

### 12.6.4 Setting the menu language

The menu languages German and English are available. The setting is taken out in the menu "Settings", then click on "Language".

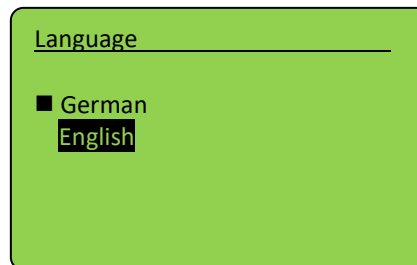

Select the desired language with the keys  $\nabla$  and  $\triangle$  and confirm with  $\checkmark$ .

### 12.6.5 Status

Here status information are given:

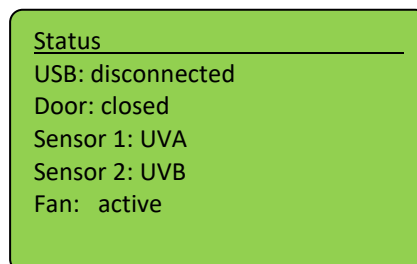

### 12.6.6 Sensor Info

Sensor-specific information can be called up under the menu item. Only connected sensors appear in the info menu.

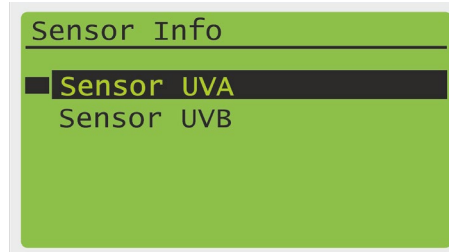

Display information about the sensor. If no sensor is connected, this menu item is not displayed.

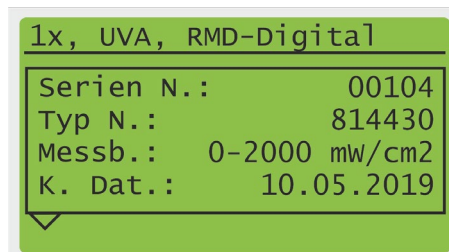

### 12.6.7 USB-Settings

This menu item enables or disables USB output and control:

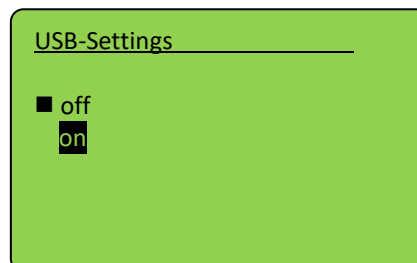

You are requested to set the send time. This is the time interval between automatic status information.

### 12.6.8 Dec.-separator

This menu item changes decimal separator for USB output:

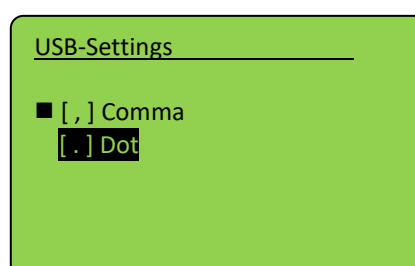

## 12.7 Internal settings

Using this menu you can set the system settings. Therefore enter the PIN code, see *chapter technical data*, must be entered.

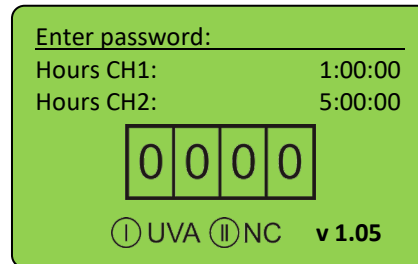

Even without PIN the operational hours, connected sensors and firmware version are displayed. After entering PIN and confirmation with OK you can change system settings:

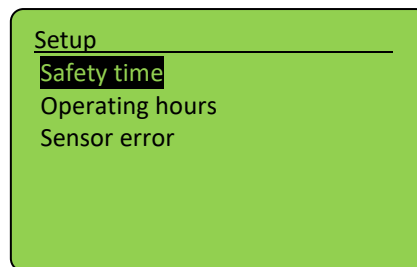

### 12.7.1 Safety time

Timing values can be adjusted in menu "safety time". See delay time, max. time and waiting time.

#### Delay time

The delay time is the time, which the UV-AB-Mat waits until it starts to monitor the sensor signal. It should be as long as the lamps need to get on a constant irradiancy delivery.

#### Max. time

Max. time is a safety function. After reaching this time the irradiation is stopped. This value should be programmed carefully, because it can be very important e.g. sunburn through a wrong input of the dose can be prevented.

#### Waiting time

The waiting time is the time after the irradiation which must be waited to start a new irradiation. This time should be so long, that double irradiation is to be excluded. It should be set at least to **3 seconds** to prevent immediate user restart.

### 12.7.2 Operating hours

The user may reset the lamps operating hours using the menu item. Reset must be confirmed by pressing ▷.



Note that the displayed operating hours are only stored if an irradiation is stopped by UV-MAT. If the UV-MAT / irradiation chamber is switched off during irradiation the operating hours aren't stored and so faulty.

### 12.7.3 Sensor errors

Setting to select if sensor errors abort the irradiation or not.

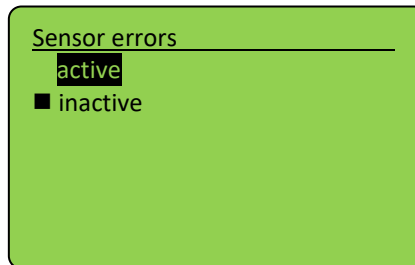



## 13 Remote Operation\*

Remote operation is required if the UV-MAT and the BSH-02 are to be controlled via a USB interface. The remote mode cannot be selected via the menu. In remote mode it is not possible to operate the unit.



Remote operation is selected by applying the USB bus voltage to the USB port. The USB bus voltage must be applied when starting the UV-MAT.

Prior setting USB-Settings: active must be selected

After successful initialization, remote operation is displayed as follows:



Communication takes place as ASCII communication,

The UV-MAT automaticall transmits when set USB to active.

Only one command/query is processed simultaneously



Communication is available after initialization of the LED system. Depending on the version, initialization may take a few seconds.

### Definitions:

- Baud rate: 115200 baud
- Parity: None
- Data-Bits: 8
- Stop-Bit: 1

## 13.1 Software Installation

**For the installation, please proceed as follows:**

- 1.) If necessary, disconnect the connection of the UV-MAT with the PC.
- 2.) Start the installation with "setup.exe" in the master data of the Software CD. Follow the instructions of the installation program.



The driver installation is executed automatically as virtual COM port.

- 3.) After completing the installation, connect the UV-MAT with the PC. The UV-MAT is integrated as a virtual, serial interface. The driver installation is taken out automatically under Windows 7.

## 13.2 Connecting with the PC

Connect the UV-MAT with the PC and switch it on. The screen displays the message "REMOTE".

Once the UV-MAT is connected with the PC, it does not react to any keystroke. Disconnect the connection with the PC and the UV-MAT continues working autonomously.

## 13.3 Software - UV-MAT Control

The software "UV-MAT Control" is used to control the BSH-02 with UV-MAT by PC. The software makes it possible:

- Switching lamp channels on and off
- Change the power (of the lamp channels)
- To use a timer for the lamp channels
- To use one dose for the lamp channels
- Save and load settings as presets (software-side)

The software is divided into several sections. At the bottom of the software is a status bar with various notes.

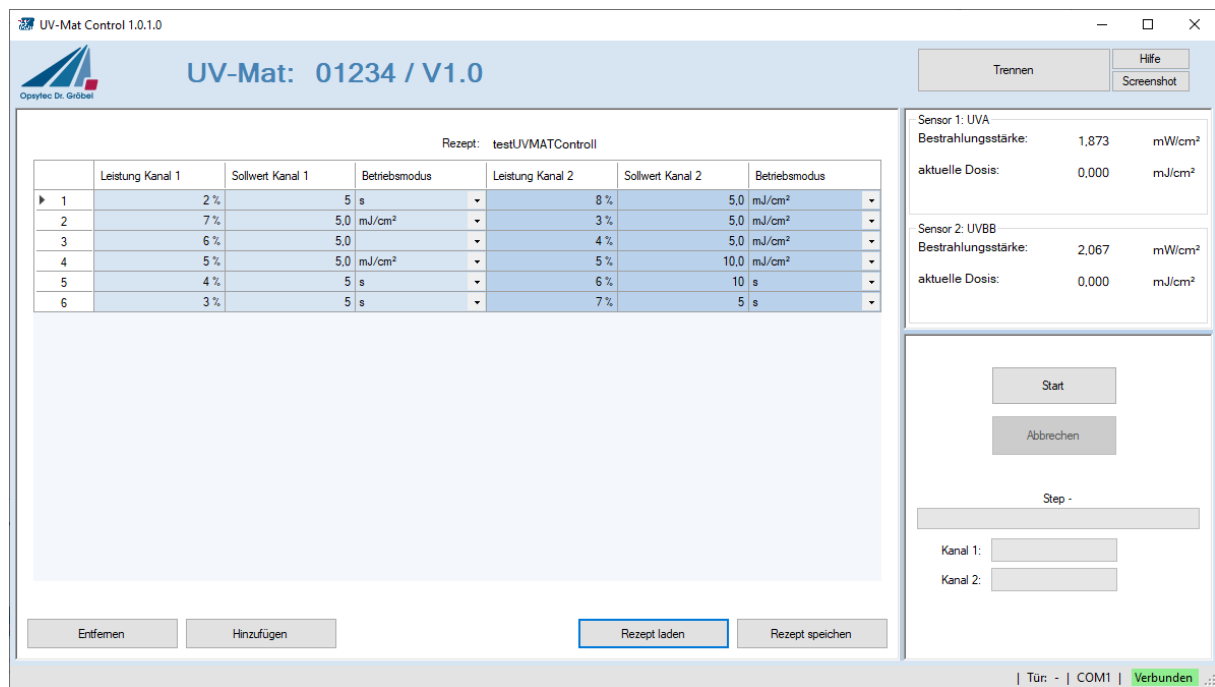

The functions are described below:

### Above

**UV-Mat: 01234 / V1.0**

Shows the serial number of the connected UV-MAT

**Trennen**

Connects or disconnects the UV-MAT from the PC and displays the connection status:

- Connected → separates the connection to the UV-MAT
- Not connected → connects the UV-MAT

**Screenshot**

Creates / saves a screenshot to document the irradiation

**Hilfe**

For further information

### Device control

The left area of the software is for control and monitoring. Here an overview table with all services, times and dose values for the channels is displayed.

Rezept: testUVMATControl

	Leistung Kanal 1	Sollwert Kanal 1	Betriebsmodus	Leistung Kanal 2	Sollwert Kanal 2	Betriebsmodus
▶ 1	2 %	5 s	▼	8 %	5,0	mJ/cm <sup>2</sup> ▼
2	7 %	5,0	mJ/cm <sup>2</sup> ▼	3 %	5,0	mJ/cm <sup>2</sup> ▼
3	6 %	5,0	mJ/cm <sup>2</sup> ▼	4 %	5,0	mJ/cm <sup>2</sup> ▼
4	5 %	5,0	mJ/cm <sup>2</sup> ▼	5 %	10,0	mJ/cm <sup>2</sup> ▼
5	4 %	5 s	▼	6 %	10	s ▼
6	3 %	5 s	▼	7 %	5 s	▼

The table is used to select the channels, to display the currently set power intensity and to display the channel status.

From the right-hand side there are various control functions for the irradiation together with the Start/Cancel button.

Sensor 1: UVA

Bestrahlungsstärke: 0,369 mW/cm<sup>2</sup>

aktuelle Dosis: 1,930 mJ/cm<sup>2</sup>

---

Sensor 2: UVBB

Bestrahlungsstärke: 1,029 mW/cm<sup>2</sup>

aktuelle Dosis: 3,742 mJ/cm<sup>2</sup>

---

Start

Abbrechen

Step 1 / 6

Kanal 1:  Zeit

Kanal 2:  Dosis

The progress of the process is displayed in the table:

	Leistung Kanal 1	Sollwert Kanal 1	Betriebsmodus	Leistung Kanal 2	Sollwert Kanal 2	Betriebsmodus
▶ 1	2 %	5 s	▼	8 %	5,0	mJ/cm <sup>2</sup> ▼
2	7 %	5,0	mJ/cm <sup>2</sup> ▼	3 %	5,0	mJ/cm <sup>2</sup> ▼
3	6 %	5,0	mJ/cm <sup>2</sup> ▼	4 %	5,0	mJ/cm <sup>2</sup> ▼
4	5 %	5,0	mJ/cm <sup>2</sup> ▼	5 %	10,0	mJ/cm <sup>2</sup> ▼
5	4 %	5 s	▼	6 %	10	s ▼
6	3 %	5 s	▼	7 %	5 s	▼

The process step is defined in the table. Example:

Channel 1 2% power for 5 s, channel 2 8% power for a dose of 5 mJ/cm<sup>2</sup>

### Software taskbar

At the bottom of the software is a bar with various functions: The right part of the bar is used to display errors and messages

Errors and messages appear in the display for 3 s, errors are highlighted in red. The last ten messages are displayed here while the mouse pointer is resting.

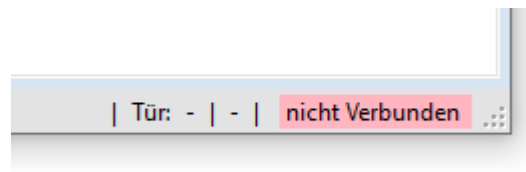

The left area is for displaying traffic jam messages

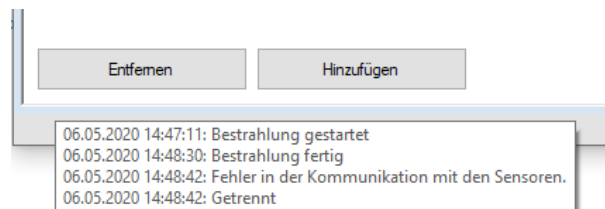

## 13.4 Working with the software

Make sure that the UV-MAT is connected to the PC and the BSH-02 is switched on. Please note that the UV-MAT must be in remote mode so that the display shows REMOTE.



Remote operation is selected by applying the USB bus voltage to the USB port. The USB bus voltage must be applied when starting the UV-MAT.

When the software is opened, one of the UV-Mats connects automatically.

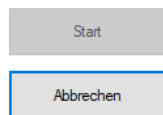

Press Start to start the irradiation with the set sequence.

Press Cancel to cancel the irradiation with the set sequence.



Here steps can be removed by marking a line or new steps can be inserted.

Here preset "Preset" / "Recipes" can be loaded and saved

**Presets:**

Presets are saved as \*.csv files and can be viewed in an editor if necessary. Example:

```
testUVMATControll.csv
Date (dd.mm.yyyy); 29.48.2020
Software version number; 1.0.0.0
Number of Steps; 6

*****

power channel 1; setpoint channel 1; operating mode 1; power channel
2; setpoint channel 2; operating mode 2;
*****

2;5;s;8;5;mJ/cm2;
3;5;s;7;5;s;
4;5;s;6;10;s;
5;5;mJ/cm2;5;10;mJ/cm2;
6;5;mJ/cm2;4;5;mJ/cm2;
7;5;mJ/cm2;3;5;mJ/cm2;
*****
```

### 13.5 Datalogging\*

With setting USB-Active the UV-MAT sends status information to on a regular base, e.g. every second. The following software gives an example about the data logging functions of the chamber:

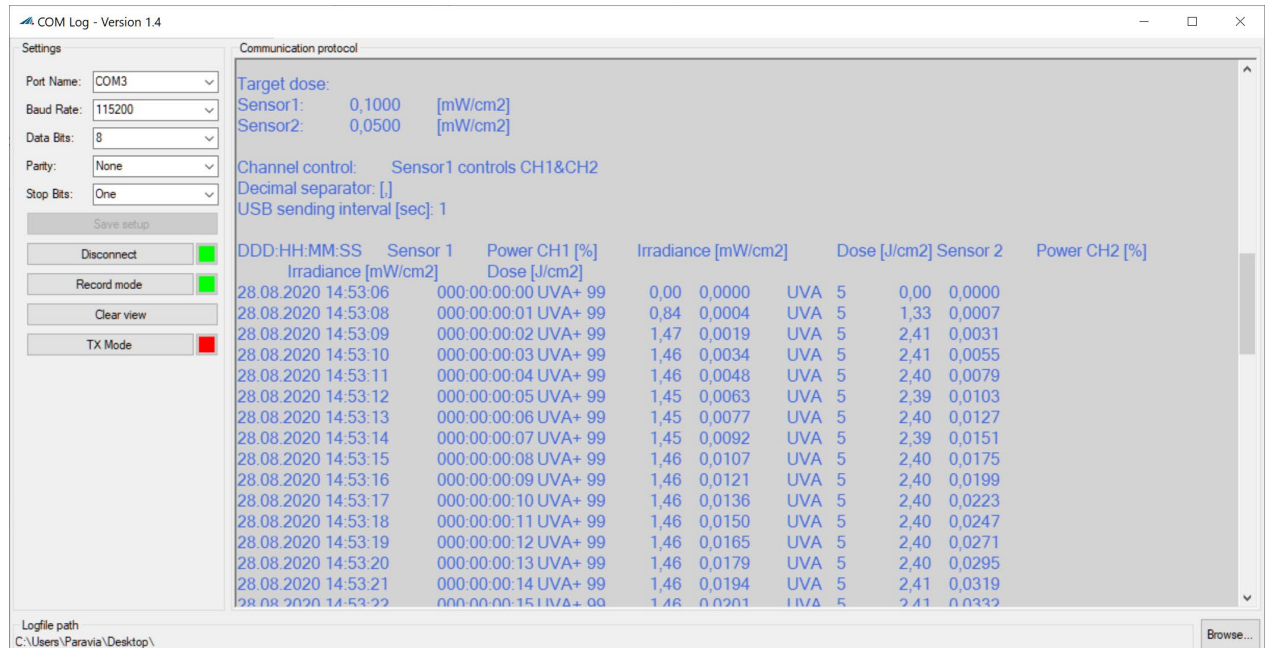
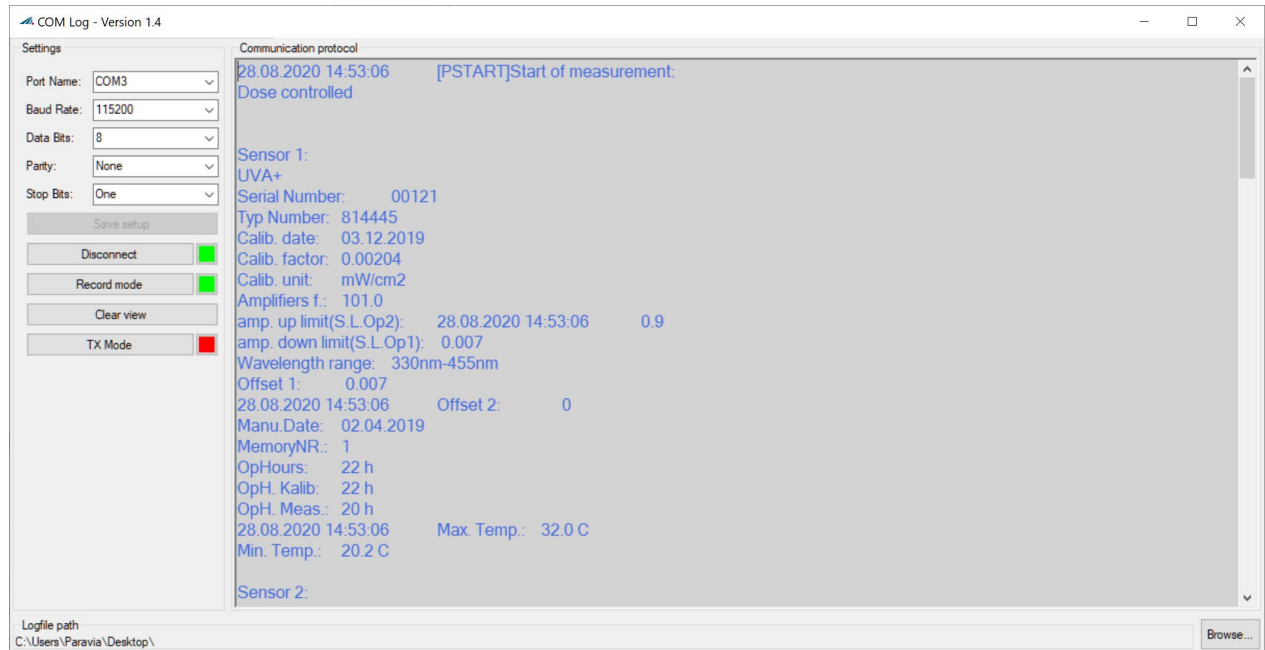

## 14 Maintenance



This chapter is intended for qualified users with maintenance tasks.

The system is largely maintenance-free. Clean the optical components only if necessary.

Turn the irradiation chamber off with the power switch. Disconnect power plug from mains.

The BSH-02 is a combined system that needs only cleaning, lamp exchange and recalibration as maintenance.

For cleaning we recommend to make this only on demand and not on a regular base as the side mirrors and sensor surface are sensitive to scratches.

Please use Isopropanol in a UV IR grade to clean sensor/sensors.

Mirrors are cleaned by pressurized air or Isopropanol and a very soft paper towel.

Also UV lamps are cleaned by pressurized air or Isopropanol and a very soft paper towel.

As this is a combined system we may need BSH-02 and UV-MAT in case of repair. Some spare parts can be changed by customer. Note, it is not recommended to change parts other than UV lamps by yourself. Warranty on spare parts will only be provided if installation and service is done by us.

For recalibration we need the sensor only.

The following table gives some maintenance steps as recommendation:

	<b>⚠ WARNING</b>
	<p><b>Risk of injury! Risk of Burns!</b>          During the irradiation the lamp temperature may rise up to approx. 50° C.</p>

	<b>⚠ CAUTION</b>
	<p><b>Risk of Damage</b></p> <ul style="list-style-type: none"> <li>• Skin fat and dirt are absorbent in the UV and visible spectral range.</li> <li>• Avoid fingerprints on the optically components, sensor surfaces, lamps and reflectors. If necessary, the components must be cleaned carefully with Isopropyl.</li> </ul>



No.	Maintenance Item	Procedure	Recommended frequency
1	Overall checking and cleaning of the machine	Cleaning of bottom side from process chamber. Accumulated dust clean-up, rust check, peeled paint check, leak, broken switch, and damaged covers, otherwise replace it.	Semi-Annual
2	Sensor checking	1. Check sensors, must be free from dirt, otherwise clean / recalibrate it.	Monthly
3	Optical components cleaning	0. Visual inspection of mirrors. Mirrors must be clean. Small dirt can be accepted as the mirrors are sensitive to scratches. Clean only on demand.	Monthly
		1. In case cleaning is needed, use pressurized air or Isopropanol (UV-IR Grade) and a very soft paper towel. Softly clean mirror from left to right, top to bottom. Must be free from cracks and dirt, otherwise replace to new one.	On Demand
4	Door contact checking	Verify and check door contact by its physical appearance. Replace if necessary.	Semi-Annual
5	Intensity checking	Check and get the actual irradiance of the machine using UV sensor (must be calibrated). (Write Value)	Monthly
6	Lamp change	Exchange UV lamps if irradiance is not high enough.	On Demand
7	Calibration	1. Check for calibration by comparison measurement or calibration date.	Annual
		2. Send to manufacturer if recalibration is necessary.	
8	Wiring check	Check all wiring connection for any possible damage or loose connection. Replace if necessary.	Every 6 Weeks
9	Cleaning	Clean the machine body (outside) using wiper to remove dust and dirt	Daily

Only carry out cleaning work on the sensor as required. This gives you the best possible stability. Clean exclusively with isopropanol (UV-IR-GRADE), with oil-free compressed air or with clean, lint-free cloths.

Wear clean, lint-free gloves.

Apply the cleaning agent only to the cloth, only moisten.

The cleaning agent could get inside and cause damage to property.

Wipe with little pressure, in a circular motion over the surfaces.

Then remove all residues of the cleaning agent.

### 14.1 Calibration

We recommend to have the sensors used calibrated every year by the manufacturer to ensure accurate measurement results.

### 14.2 Errors / Malfunctions

The following notes and error messages address the user. The instructions shall help to ensure the proper operation. For this purpose, possible causes and remedies are indicated.

Function / Display	Meaning	Actions
Fan does not run after switching irradiation on	No supply voltage.	Check cables and connections. Check supply voltage.
System does not respond	Wrong mode, showing remote	Disconnect USB cable
The irradiance is too low	lamps aged  lamps dirty  lamps not correctly parametrized / dimmed  Sensor error	Exchange lamps  Clean (e.g. with ISOPROPYL) Set power (2-100%)  Check or recalibrate sensor

## 15 Technical Data

<b>General data</b>	
Ambient temperature	+15 to 30 °C
Storage temperature	+ 5 to 60 °C
Humidity	< 80% non-condensing
Cooling	Air cooling
Maximum housing temperature	< 60 °C
Dimensions, chamber	~58 cm x 40 cm x 47 cm (L x T x H)
Interior dimensions sample plate	50 cm x 32 cm
Interior height	22 cm
Weight, chamber	~31 kg
Type	tabletop device
Noise Emission / Noise Declaration for Machines	<p><math>L_{pa} &lt; 70</math> dB during normal operation according DIN 45635 T. 19</p> <p>This is to declare that this product is in conformance with the German Regulation on Noise Declaration for Machines</p>

<b>Installation, minimum clearances</b>	
Installation of the system	horizontal
Minimum clearance, above	4 cm
Minimum clearance, lateral	4 cm

<b>Power Supply and Connections</b>	
Operating voltage and frequency	see type plate on chamber
Maximum input power	see type plate on chamber, typical 1300 W
Connection UV-MAT	rear mult-pole plug
Sensor connections	2 pieces, fully digital
PC interface	USB 2.0
Virtual Serial Port	<p>Baud: 115200</p> <p>Databits: 8</p> <p>Parity: None</p> <p>Stop Bits: 1</p>

<b>USB-Connection / Hardware- Software requirements</b>	
PC requirements	min Intel CORE i3, 2 GB Ram, >40 Gb HDD
Operating system	Windows 10 with .NET Framework > 4.0

<b>UV-MAT</b>	
Size (L x W x H)	250 x 185 x 100 mm <sup>3</sup>
Weight	2,6 kg
Power supply	DC Low voltage, by chamber only
Operational temperature	0 - 30°C
Storage temperature	0 - 60°C
Humidity	< 80%, non-condensing
Display	graphical, 128 x 64 px
Dose calculation	for all irradiance readings > 0,1 mW/cm <sup>2</sup> to avoid offset failure
Size (L x W x H)	250 x 185 x 100 mm <sup>3</sup>

<b>UV-MAT Code number</b>	
Code number	7243

<b>TECHNICAL DATA SENSORS</b>	
Measuring range	See type, typically 0 - 100 mW/cm <sup>2</sup> to 0 - 10 W/cm <sup>2</sup>
Resolution	0.01 mW/cm <sup>2</sup>
Dynamic range	up to 10 <sup>7</sup>
AD conversion	24 bit
Dimensions	Ø 40 mm, h 35 mm
Optical surface	Ø 6 mm
Weight	160 g
Connection cable	2 m
Operating temperature	0 to 40 °C
Storage temperature	-20 to 60 °C
Air humidity	<80%, non-condensing
Cosine correction	yes
Calibration	yes, traceable to PTB / NIST
frequency of checks (Recalibration)	12 months

Spectral ranges of the sensors	
UVC	200 - 280 nm

Lamps	
Type	UVI 140 U
Power	150 W
Main emission	UVC
Total number of lamps	5

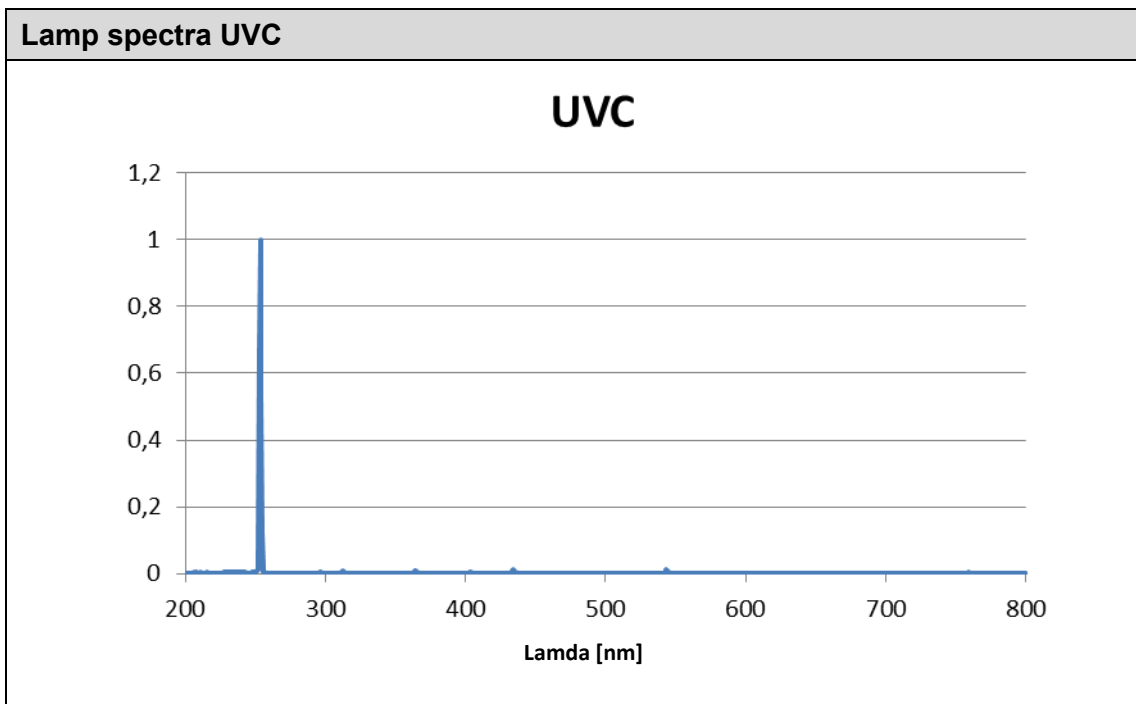

<b>⚠ WARNING</b>	
	<p><b>Risk of injury! OZONE !</b></p> <p>When using ozone-generating lamps, the exhaust air can be enriched with ozone. Ozone is harmful to health when inhaled in high concentrations through the lungs and long periods of time. Always avoid inhaling ozone.</p> <p>A suitable drainage and treatment of waste air must be ensured so that the permissible ozone workplace concentration (MAK value) is not exceeded.</p>

### Typical intensity distribution

The max. UVC irradiance on the sample table surface  $E_{max}$  75-85 mW/cm<sup>2</sup>.

The energy distribution on the drawer sheet metal has the following distribution:

Pos. Sensor		Breite: X-Richtung											
		40 mm	80 mm	120 mm	160 mm	200 mm	240 mm	280 mm	320 mm	360 mm	400 mm	440 mm	480 mm
Tiefe: Y-Richtung	40 mm	53%	59%	68%	84%	84%	89%	92%	94%	92%	87%	83%	79%
	80 mm	55%	62%	71%	89%	87%	93%	96%	97%	95%	91%	87%	83%
	120 mm	58%	65%	73%	90%	91%	96%	99%	100%	98%	94%	91%	87%
	160 mm	59%	65%	74%	90%	91%	96%	99%	100%	99%	95%	92%	88%
	200 mm	58%	64%	73%	90%	90%	95%	98%	98%	98%	94%	91%	87%
	240 mm	56%	61%	70%	86%	85%	91%	92%	94%	93%	90%	87%	84%
	280 mm	52%	58%	65%	80%	80%	82%	87%	88%	88%	86%	81%	77%
	320 mm	49%	54%	63%	76%	76%	79%	83%	83%	84%	83%	77%	70%

The front edge of drawer is at the lower end of the diagram. The brush is at the left side of the diagram and the gap for the grid is 4 cm.

### Lamp numbering

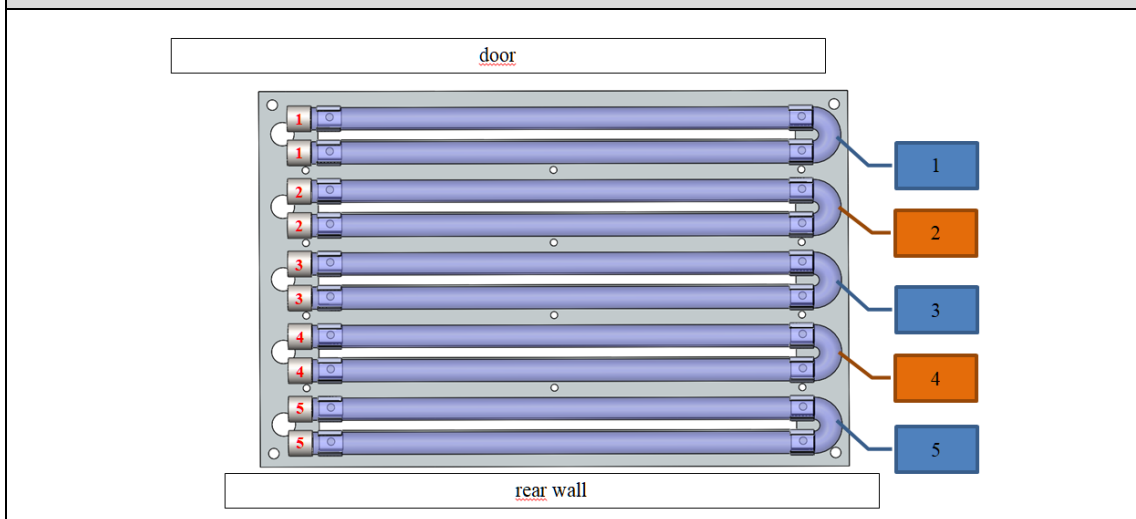

<b>Inert box*</b>	
Dimensions	404 mm x 313 mm x 111 mm
Irradiation window dimensions	350 mm x 270 mm
Air Inlet & Air outlet connector	Hose connection: diameter 10mm
Evacuatable	No
Max input pressure	0,2 bar, do not close gas outlet

## 16 Spare Parts



**When ordering spare parts, please contact:**

Opsytec Dr. Gröbel GmbH  
 Am Hardtwald 6-8  
 76275 Ettlingen  
 Germany  
 Phone +49 - 7243 - 94 783 - 50  
 Fax +49 - 7243 - 94 783 – 65

Visit our website at: [www.opsytec.de](http://www.opsytec.de)

The following spare parts are available for your system:

Designation	Part Number
Air inlet filter set	BSH-02-AIF
Air inlet cover set	BSH-02-AIC
Left internal side mirror	BSH-02-BM
Back internal side mirror	BSH-02-RM
Right internal side mirror	BSH-02-RM
Air outlet fan	BSH-02-AOF
Air outlet filter set	BSH-02-AOF
Air outlet cover set	BSH-02-AOCS
Connector end caps for cables	BSH-02-EC
Bottom plate	BSH-02-BP
Front door with internal mirror	BSH-02 BSH-02-Door
Door contact	860801L-DC
UV-MAT	specify serial number
Sensor	See sensor type
Sensor recalibration	710001
Sensor recalibration, DAKKS	17025
Other Parts	On request



## 17 Declaration of Conformity



Manufacturer :	Company name: Opsytec Dr. Gröbel GmbH Street: Am Hardtwald 6-8 City: 76275 Ettlingen Country: Deutschland
Person authorized to compile the technical documentation	Company name: Opsytec Dr. Gröbel GmbH Street: Am Hardtwald 6-8 City: 76275 Ettlingen Country: Deutschland
Product:	Irradiation chamber with UV lamps, UV dose controller UV-MAT and sensor(s)
Type designation:	BSH-02
Type number:	860 902H XXXX 860 900 XXXX 814 41X XXXX

The manufacturer hereby declares that we have developed, designed and manufactured the above product(s) under our sole responsibility and that the product complies with the following standard(s) or directive(s) in this declaration:

2014/35/EU

"Directive of the European Parliament and of the Council on the harmonization of the laws of the Member States regarding the provision of electrical equipment for use within certain voltage limits on the market (Low-Voltage Directive)".

2006/42/EG

"Directive of the European Parliament and of the Council on machinery and amending Directive 95/16/EG (Machinery Directive)".

2014/30/EU

Directive of the European Parliament and of the Council relating to electromagnetic compatibility (EMC Directive, recast)".

Ettlingen, 26.08.2020

gez. Dr. Mark Paravia